

ENIS

ATELIER
IRACI
& PARTNERS

x

bongio
MADE IN ITALY SINCE 1954

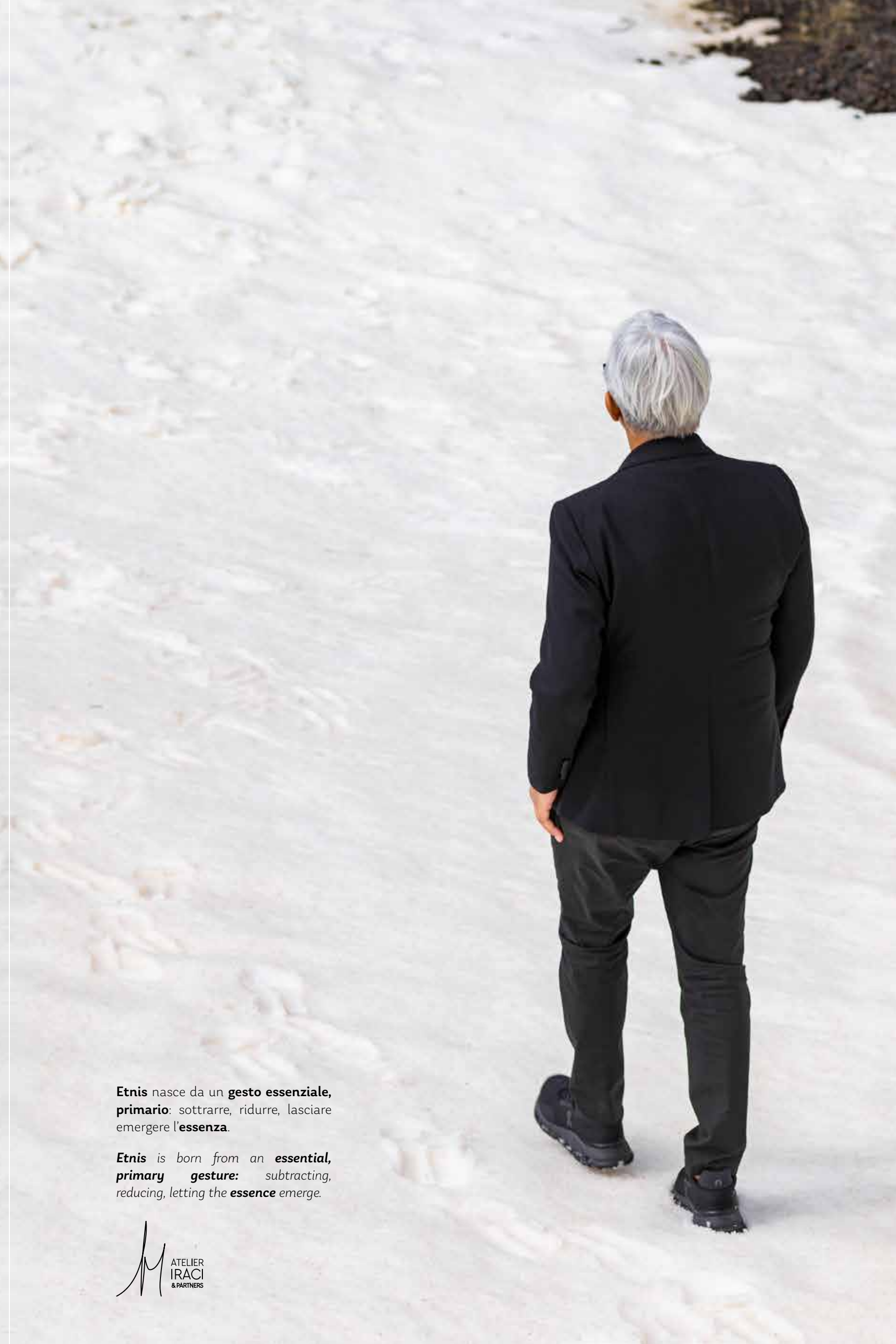

Etnis nasce da un **gesto essenziale, primario**: sottrarre, ridurre, lasciare emergere l'**essenza**.

***Etnis** is born from an **essential, primary gesture**: subtracting, reducing, letting the **essence** emerge.*



Il nome Etnis nasce dall'incontro tra due radici di significato.

Da un lato richiama **l'eco del Monte Etna**, energia geologica primordiale, luogo in cui la materia prende **forma** attraverso il tempo e la **trasformazione**.

Dall'altro il suono rimanda alla parola **Etnia**, dal greco *éthnos*: origine, **appartenenza**, identità che nasce da una **radice comune**.

The name Etnis originates from the meeting of two roots of meaning.

*On one side, it **echoes Mount Etna** — a primordial geological energy, a place where matter takes **shape** through time and **transformation**.*

*On the other, its sound recalls the word **Ethnicity**, from the Greek *éthnos*: origin, **belonging**, an identity born from a **shared root**.*

ETNIS

ATELIER
IRACI
& PARTNERS

x

bongio
MADE IN ITALY SINCE 1958



Tra questi due significati esiste un legame profondo. Se l'Etna è origine della materia, l'etnia è origine dell'identità.

Etnis si colloca in questo punto di incontro: un nome essenziale che racchiude l'idea di una **materia primordiale che diventa forma, segno, presenza.**

Between these two meanings lies a deep connection.

If Etna is the origin of matter, ethnicity is the origin of identity.

*Etnis stands at this intersection: an essential name that embodies the idea of **primordial matter becoming form, sign, presence.***

ETNIS

ATELIER
IRACI
& PARTNERS

x **bongio**
MADE IN ITALY SINCE 1968



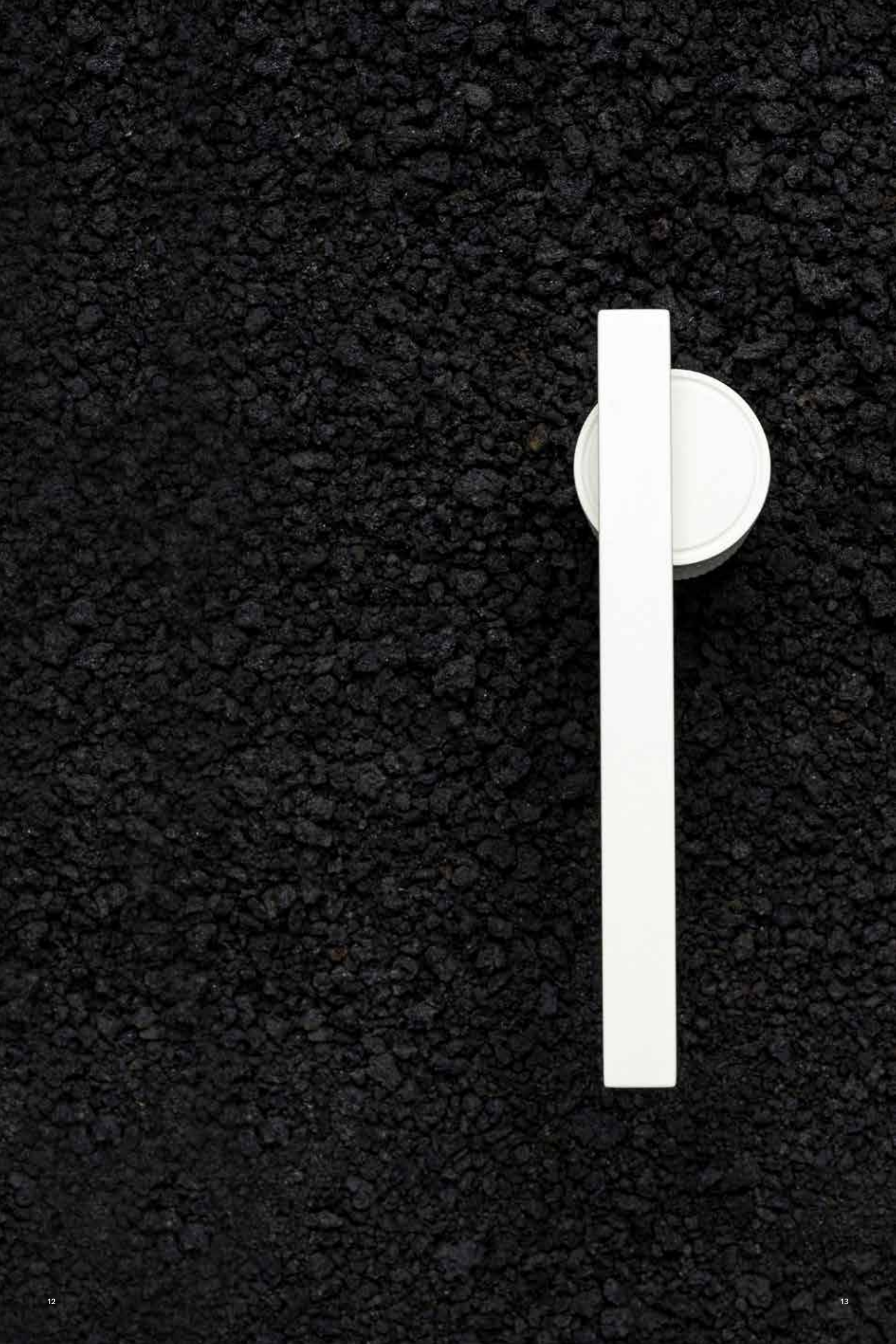



La **forma** si libera da ogni superfluo e **diventa segno**, equilibrio tra materia e misura.

Un progetto che trova la propria forza nella precisione e nella sottrazione, dove ogni elemento è ricondotto alla sua necessità.

Form is freed from all excess and **becomes a sign** — a balance between matter and measure.

A design that finds its strength in precision and reduction, where every element is brought back to necessity.





MATERIA





Un equilibrio tra rigore geometrico e forza materica, come un **segno inciso nella roccia**. La materia si fa compatta, quasi geologica, capace di trasmettere una sensazione di solidità e permanenza.

*A balance between geometric rigor and material strength, like a **mark carved into rock**.*

The material becomes compact, almost geological, capable of conveying a sense of solidity and permanence.





LUCE





Superfici nette catturano la luce e la restituiscono con precisione, mentre la materia rivela la propria temperatura attraverso le diverse finiture.

Ogni variante diventa un modo diverso di interpretare la stessa essenza, un **dialogo tra superficie, luce e percezione**.

Clean surfaces capture light and return it with precision, while the material reveals its temperature through different finishes.

*Each variation becomes a different interpretation of the same essence – a **dialogue between surface, light, and perception**.*





ORIGINE





Etnis è presenza discreta e insieme carattere.

Un'identità asciutta, quasi un suono, che racchiude l'idea di una **materia viva resa forma.**

*Etnis is a discreet presence and, at the same time, a statement of character. A restrained identity, almost like a sound, expressing the idea of **living matter shaped into form.***







GESTO

Linee rigorose e proporzioni calibrate trasformano il rubinetto in una **piccola architettura domestica**: un oggetto essenziale che porta nel quotidiano il senso di origine, temperatura, permanenza. Un segno misurato che trova il proprio spazio nell'**architettura dell'abitare**.

*Rigorous lines and calibrated proportions transform the tap into a **small domestic architecture**: an essential object that brings a sense of origin, temperature, and permanence into everyday life. A measured sign that finds its place within the **architecture of living**.*





SCOPRI
DISCOVER

ENIS

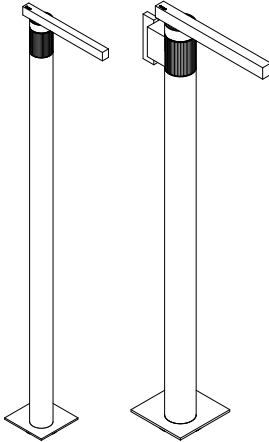
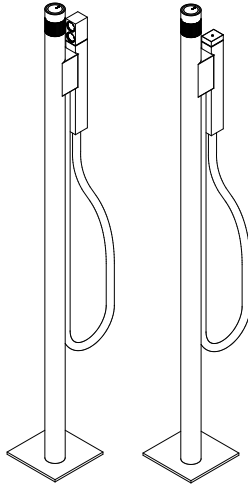
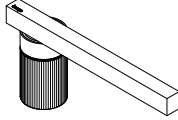
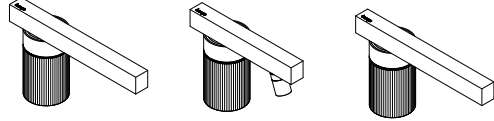
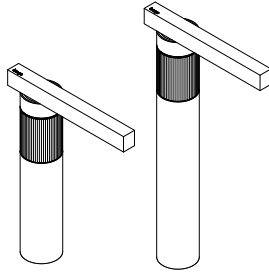
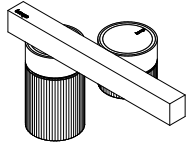
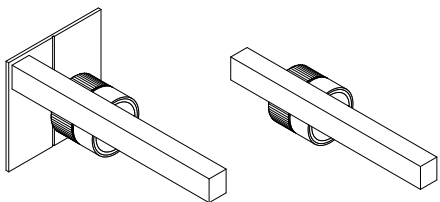
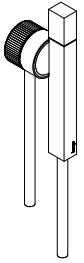
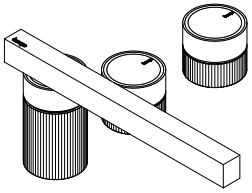
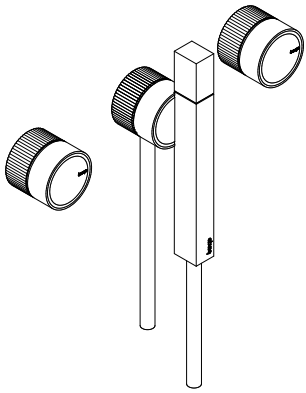
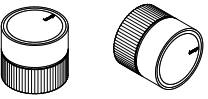
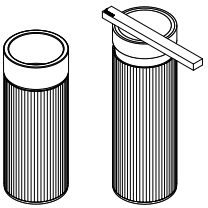
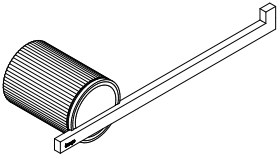
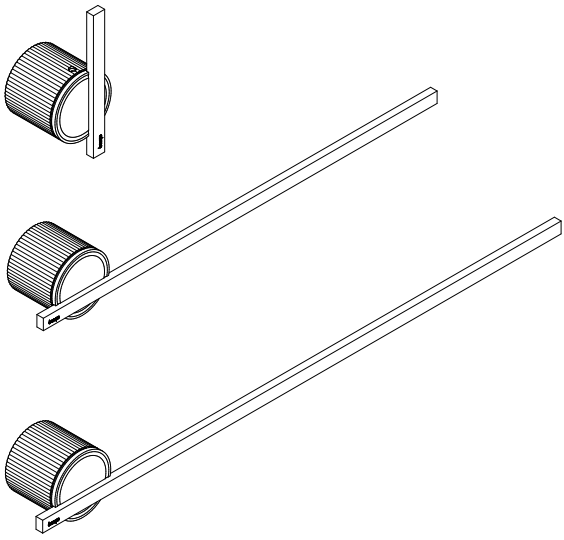

Credits:

Product Design

Antonio Iraci for Atelier Iraci & Partners

Concept and Graphic Design

Mas Communication

Photo

Alessandro Castagna



Mario Bongio s.r.l.
Via Aldo Moro, 2
28017 - San Maurizio d'Opaglio
Novara, Italia

T. +39 0322 96 72 48
F. +39 0322 95 00 12
info@bongio.it



bongio.com



