

ISTRUZIONI DI MONTAGGIO

INSTALLATION INSTRUCTIONS

**Uscita doccia
Shower exit**

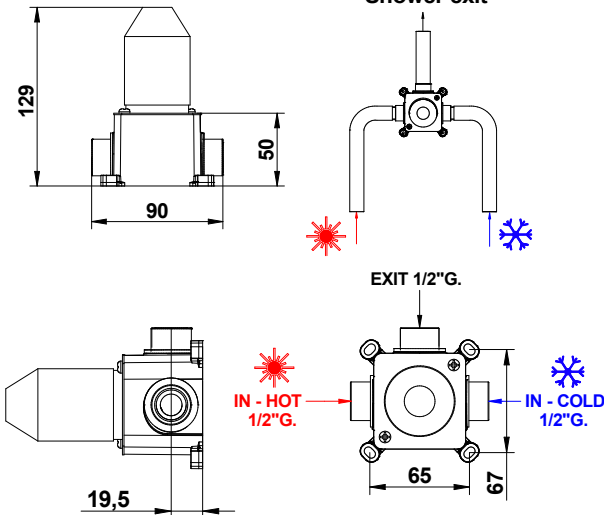

A

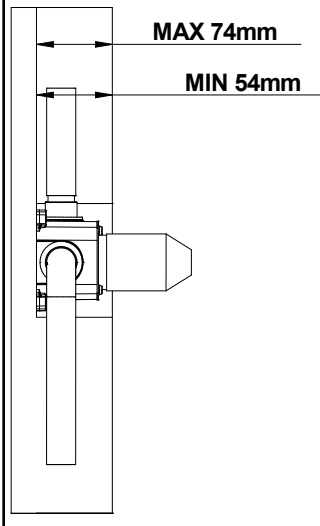

B

Installazione a muro
Verificare con livella il corretto posizionamento.
Installation into a solid wall
Place correctly into the wall verifying with level.

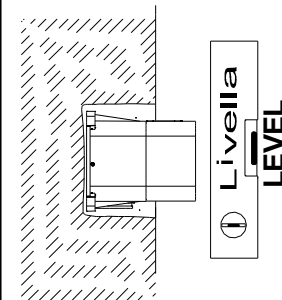

C

Viti fissaggio -- Fixing screw

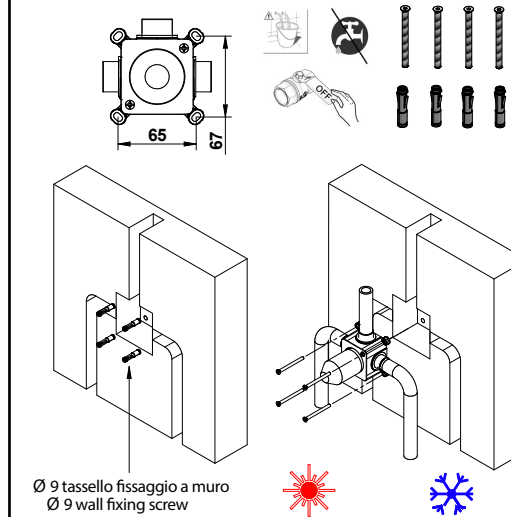

D

Collaudo impianto
Mettere in pressione l'impianto per verificare eventuali perdite.
Plant's test
Put the plant under pressure to find any leaving.

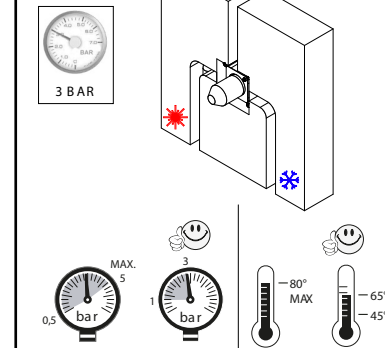

E

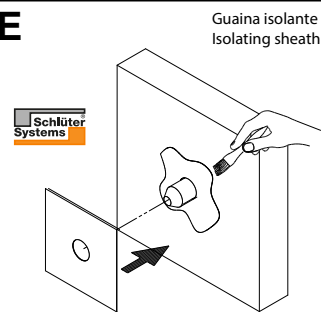

F

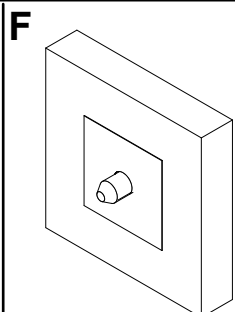

G MIN-Ø45 -- MAXØ52

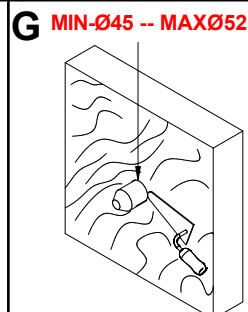

H

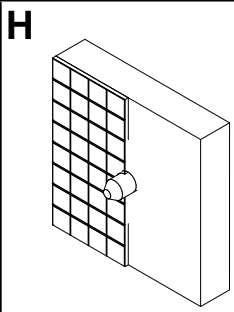

I

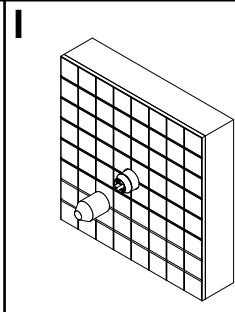

L

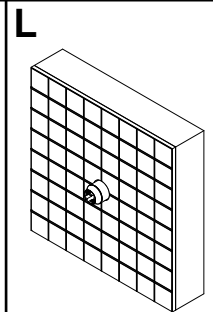

Installazione su cartongesso

Installation into acavity wall

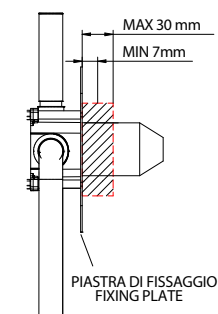

Viti fissaggio
Fixing screw

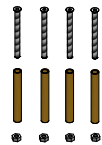

A

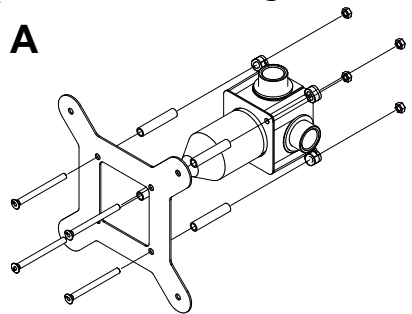

B

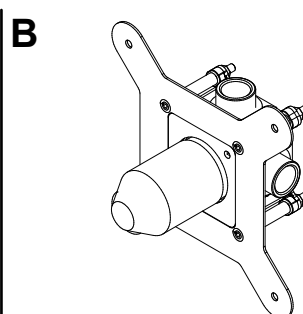

C

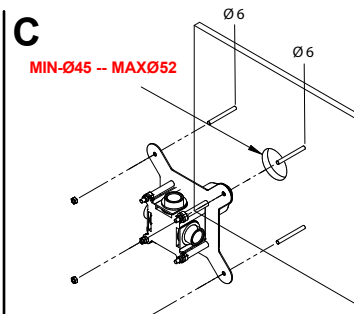

PRESSIONE MINIMA DI SERVIZIO :.....0,5 bar
PRESSIONE DI SERVIZIO MASSIMA :.....5 bar
PRESSIONE D'USO CONSIGLIATA :.....3 bar
TEMPERATURA ACQUA CALDA MAX :.....80°C
TEMPERATURA ACQUA CALDA CONSIGLIATA :.....65°C

In caso di pressione d'esercizio superiore a 5 bar è consigliabile installare un riduttore di pressione sulle tubature di alimentazione.

MINIMUM WORKING PRESSURE:.....0,5 bar
MAX OPERATING PRESSURE :.....5 bar
RECOMMENDED OPERATION PRESSURE :.....3 bar
MAX HOT WATER TEMPERATURE :.....80°C
RECOMMENDED HOT WATER TEMPERATURE :.....65°C

In case of operating pressures higher than 5 bar it is recommended to install a pressure reducer on the feeding tubes.

bongio

Installazione per miscelatore incasso
ART.09761SC01

Installation for built-in mixer
ITEM.09761SC01

Mario Bongio s.r.l.
Via Aldo Moro, 2
28017 San Maurizio d'Opaglio (NO) - Italy
tel: +39 0322 967248 fax: +39 0322 950012
www.bongio.com - info@bongio.it
© Copyright of Mario Bongio s.r.l.