

**INSTALLAZIONE BOCCA INCASSO ELETTRONICA Art.46992NEELPR
ELECTRONIC BUILT IN SPOUT ART.46992NEELPR**

bongio

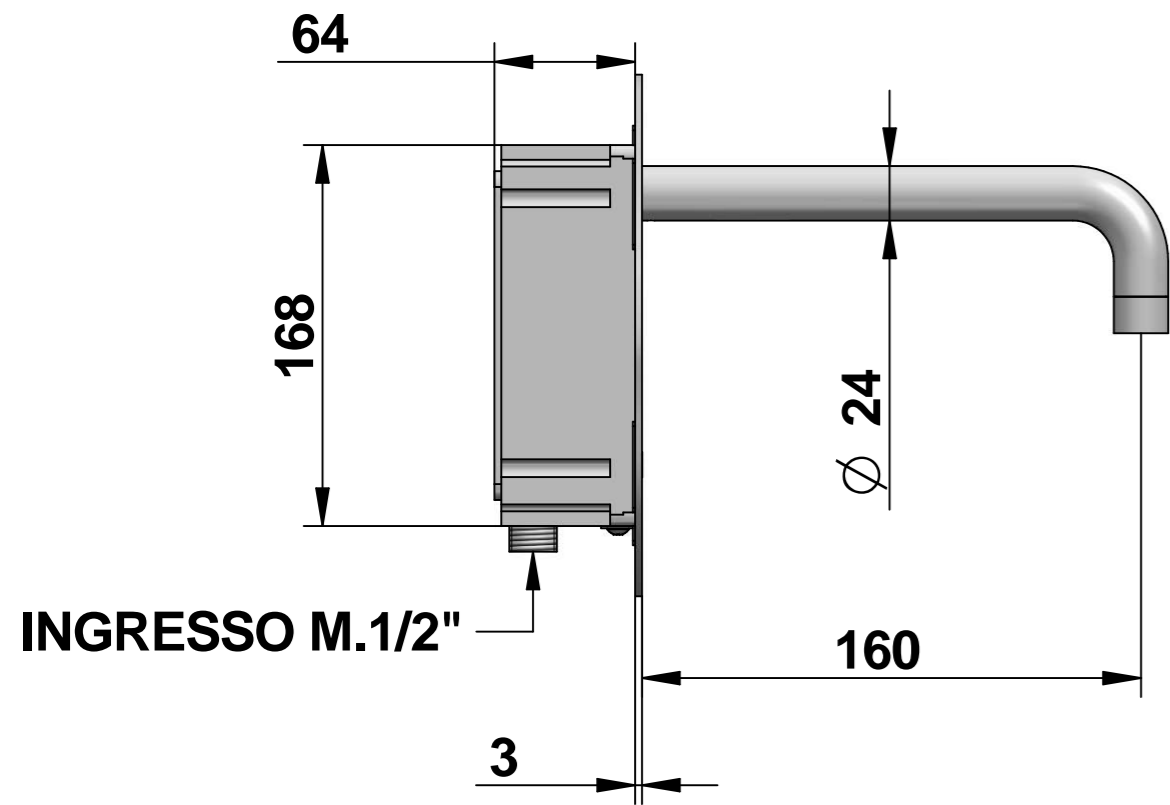

SI00100PT

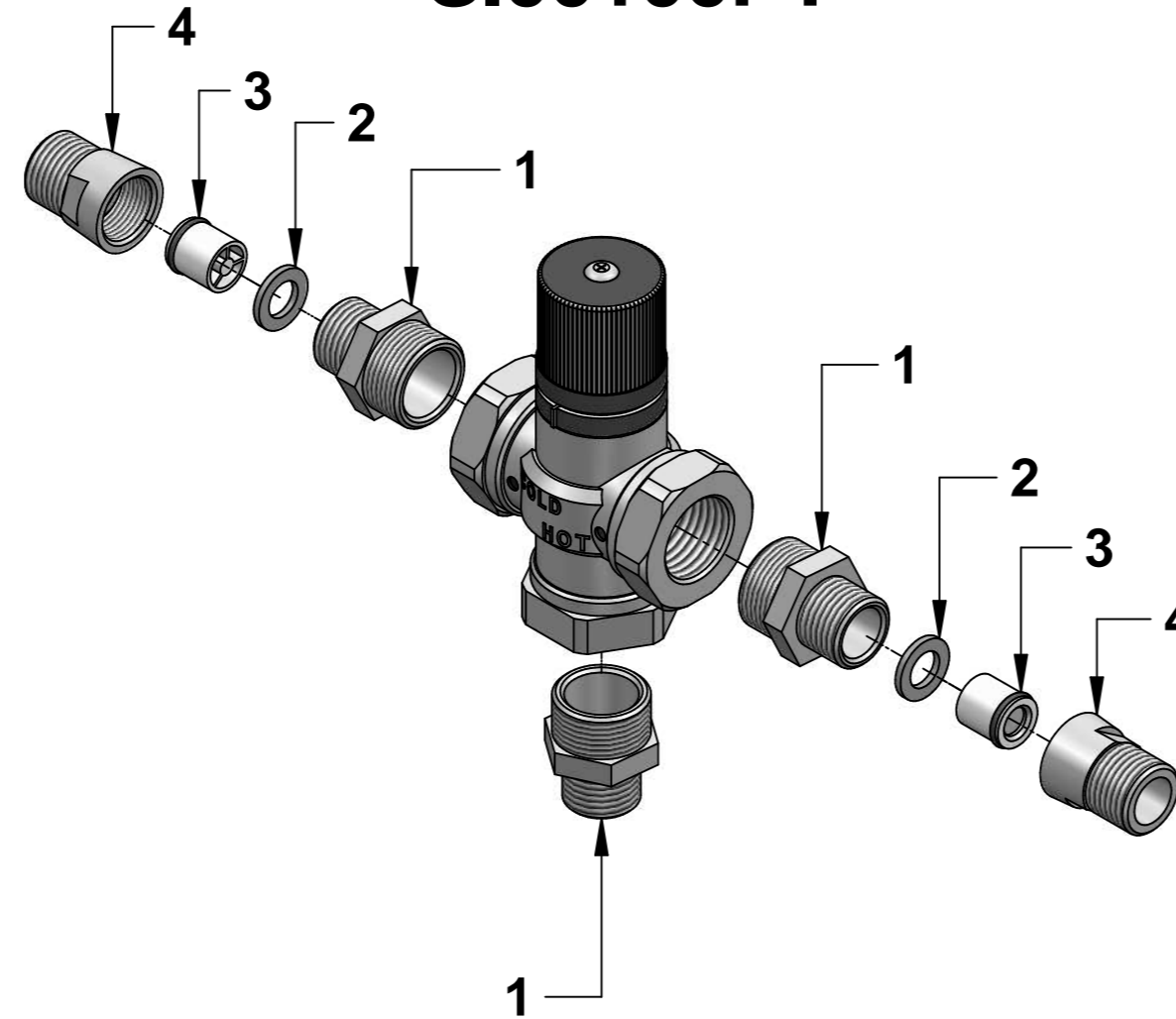

**PIASTRA FRONTALE CON PORTA BATTERIE E SENSORE
FRONT PLATE WITH BATTERY BOX AND SENSOR**

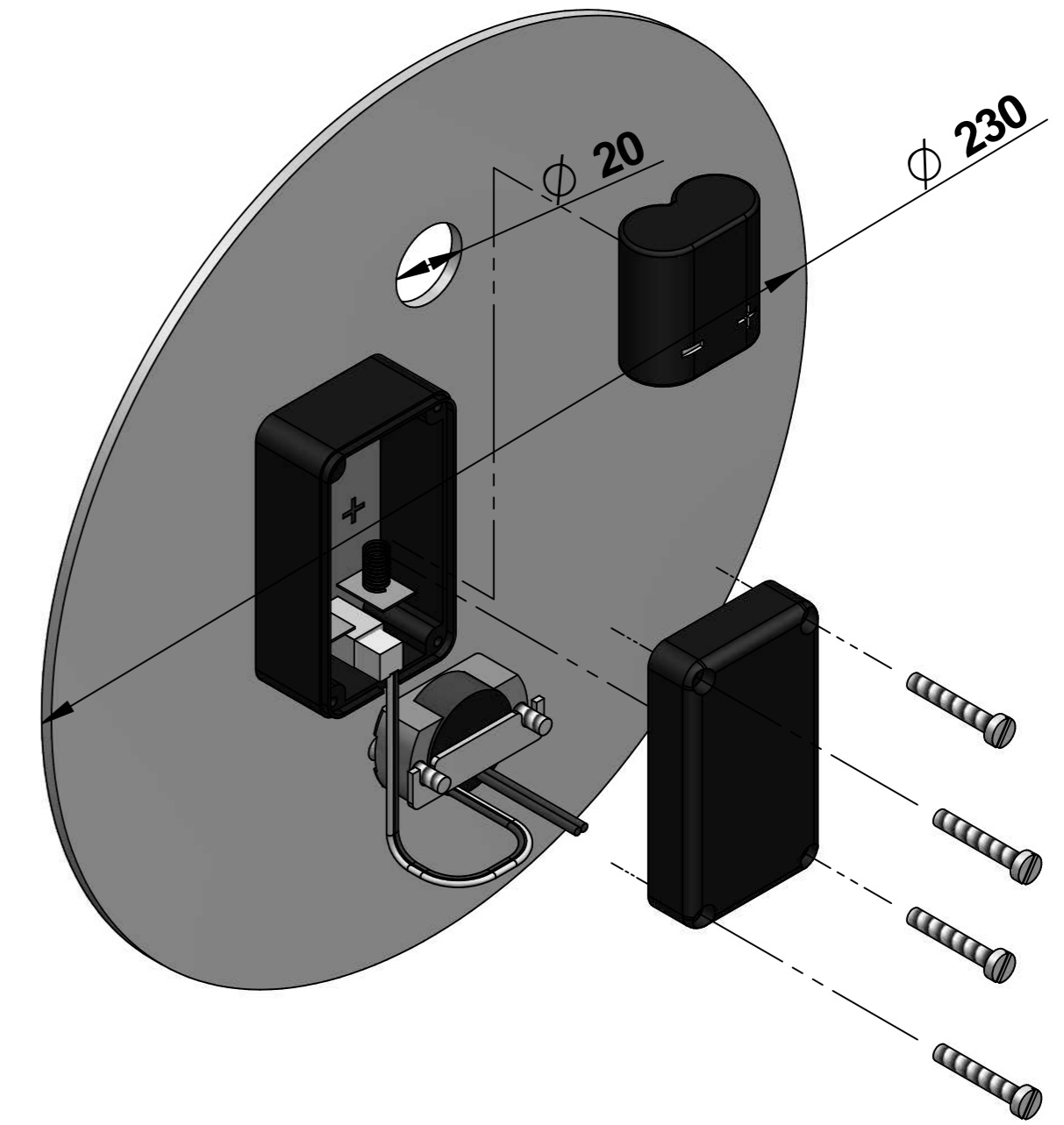

**SCATOLA INCASSO CON ELETTROVALVOLA
ELECTRO VALVE BOX**

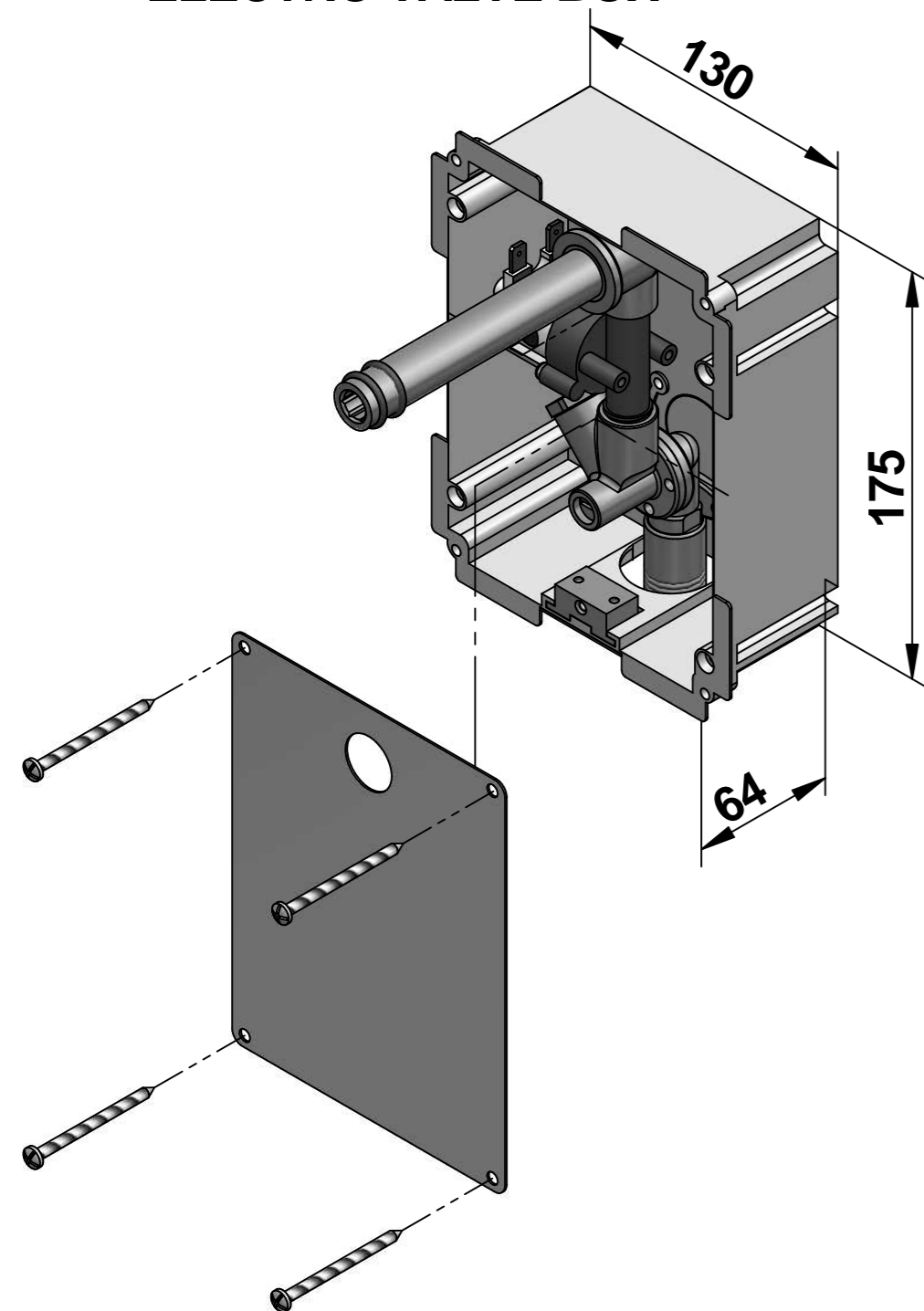

**BOCCA INCASSO DA 220
220 MMS SPOUT**

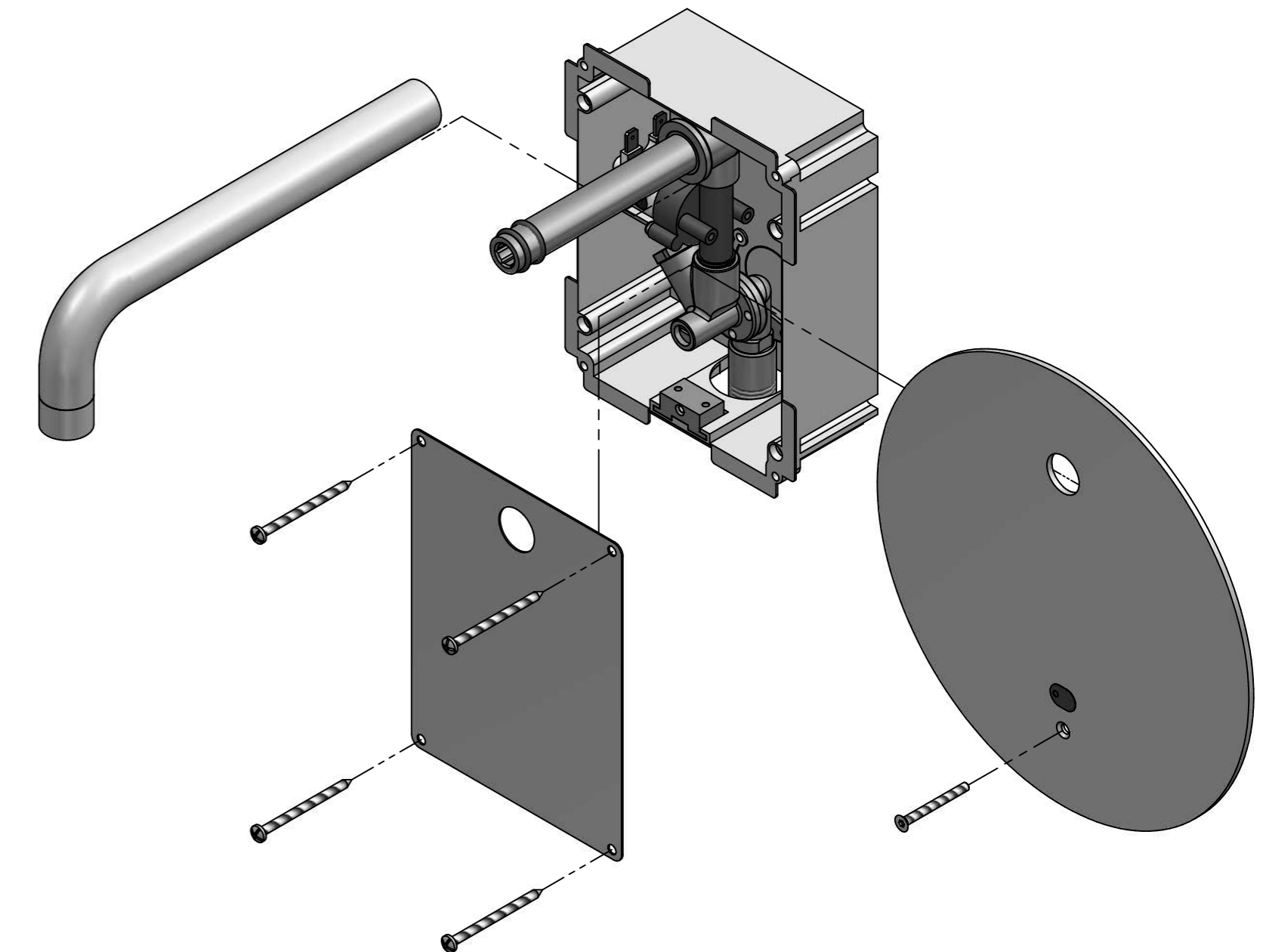
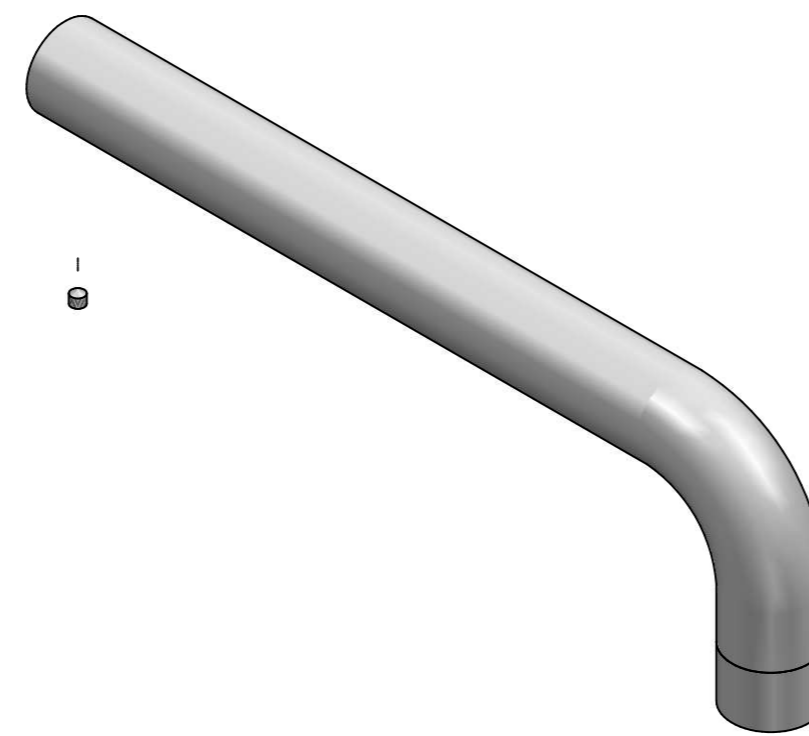

INCASSARE SCATOLA FILO MURO GREZZO.

BUILT IN THE BOX ON LINE WITH THE RAW WALL.

bongio

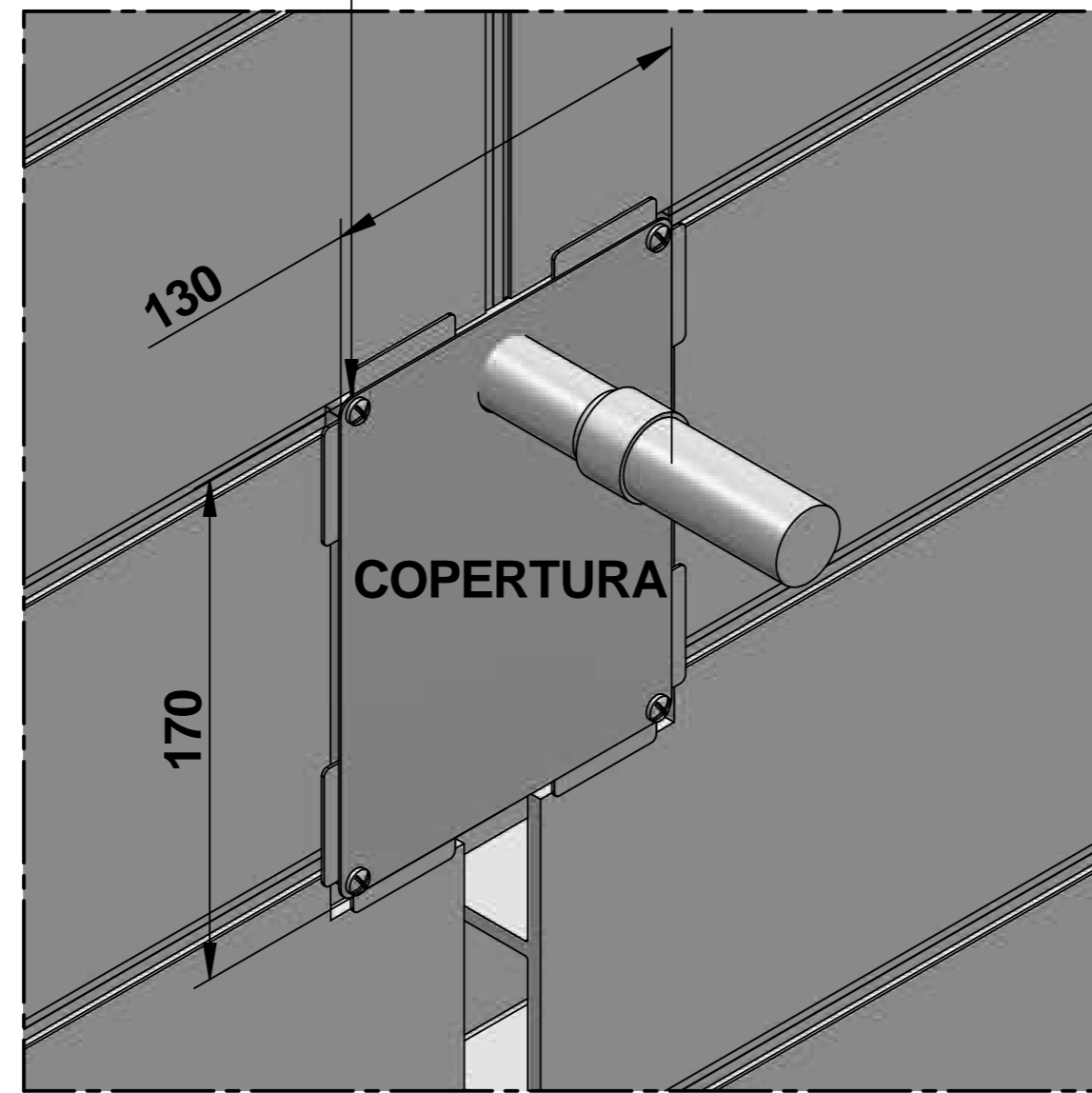
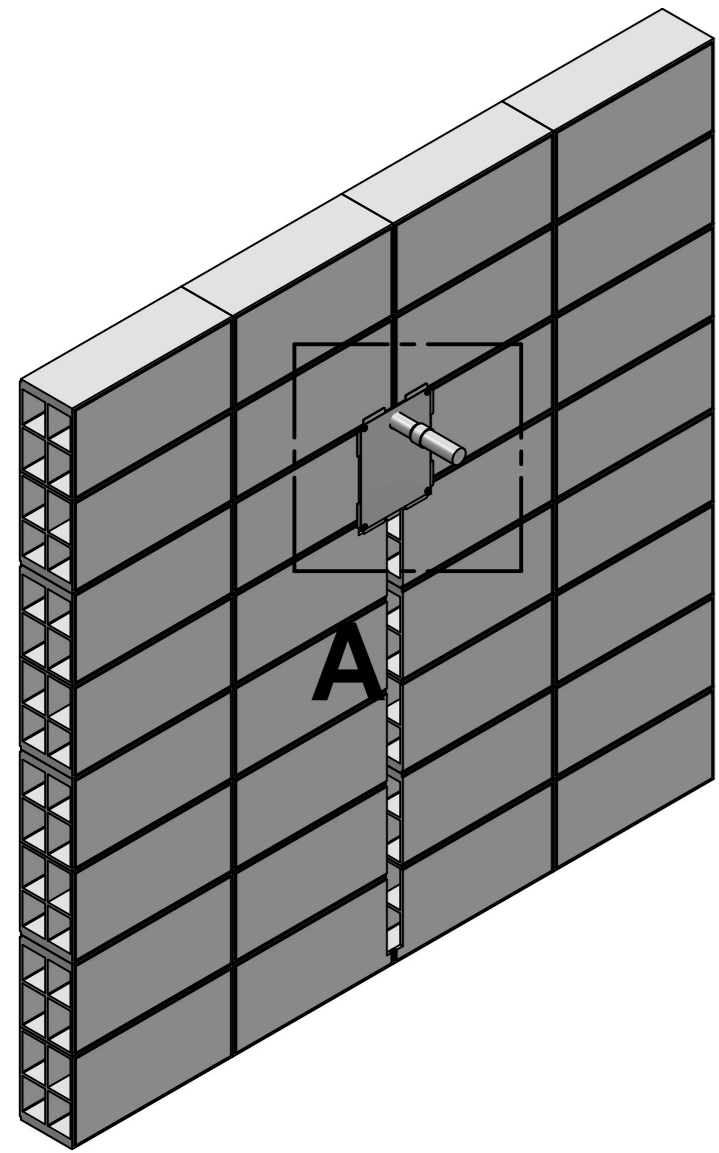

DETTAGLIO A

**CONTORNARE LA COPERTURA
CON IL RIVESTIMENTO.**

**PLACE THE TILES AROUND THE PLATE
AND NOT OVER.**

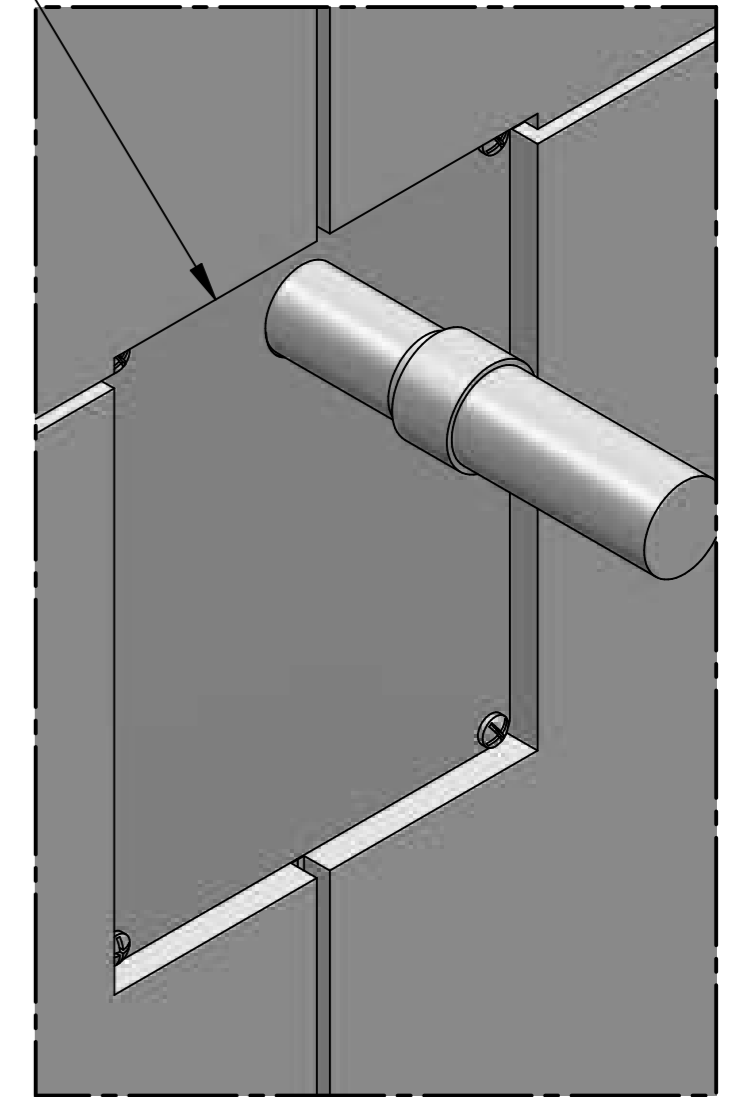
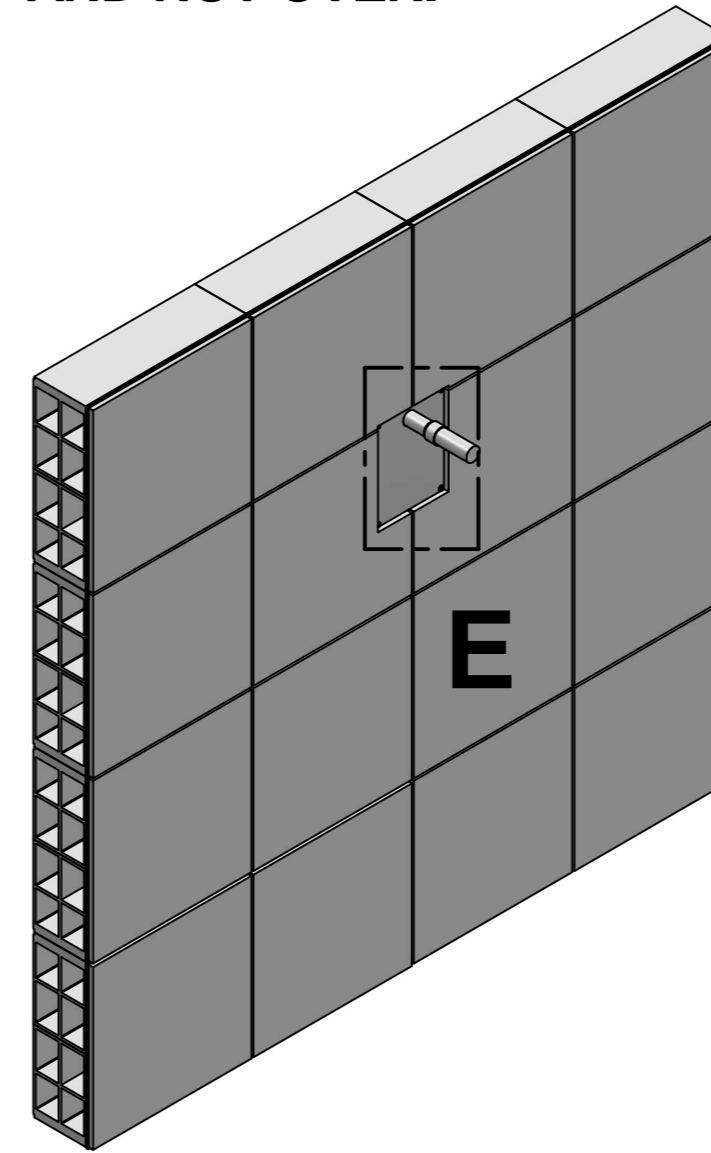

DETTAGLIO E

TOGLIERE PROTEZIONE BOCCA.

REMOVE THE SPOUT PROTECTION.

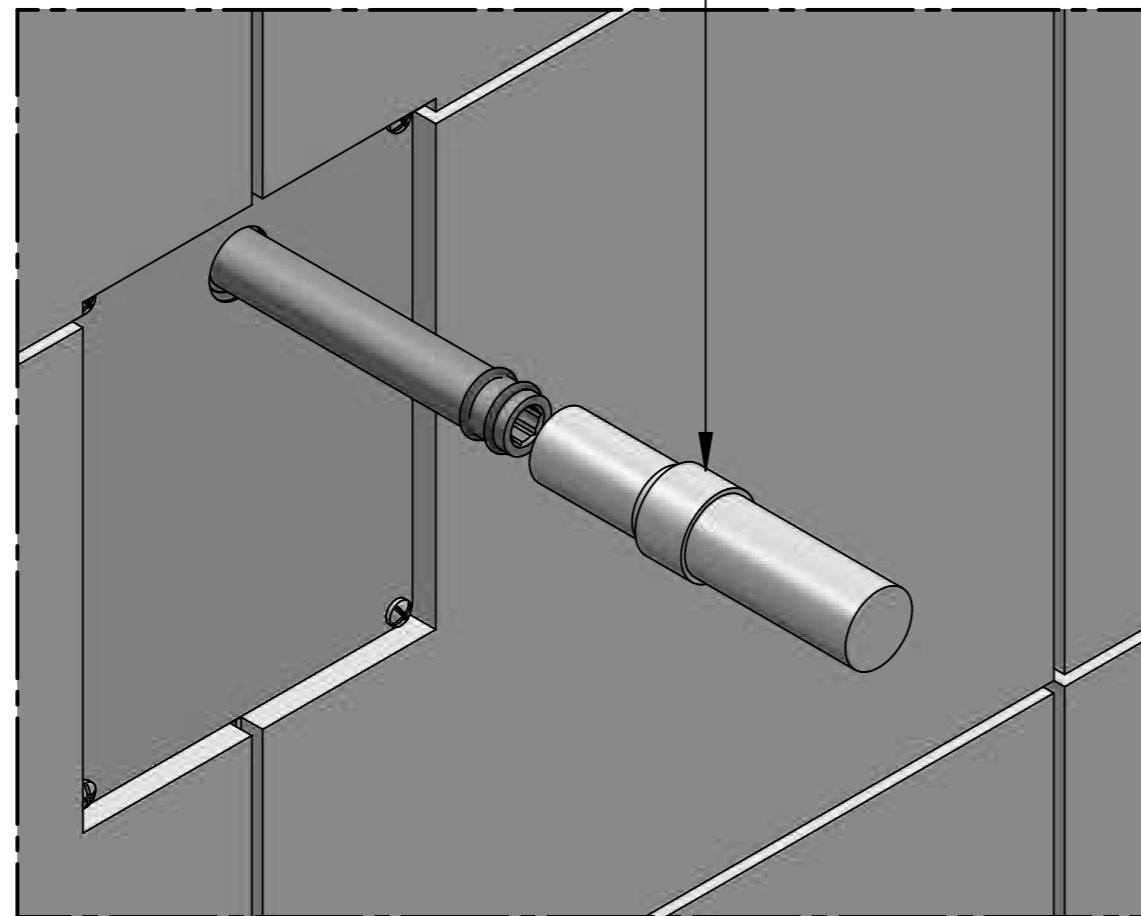
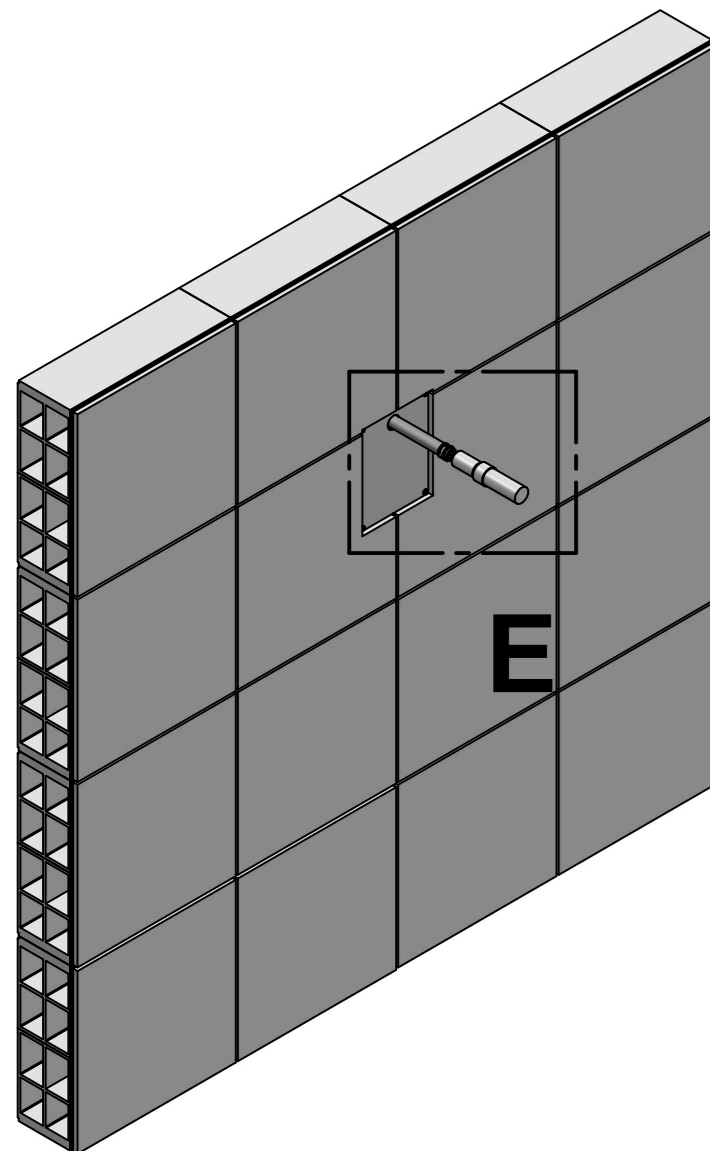

DETTAGLIO E

TOGLIERE PROTEZIONE CASSETTA.

REMOVE THE PLATE FROM THE BOX.

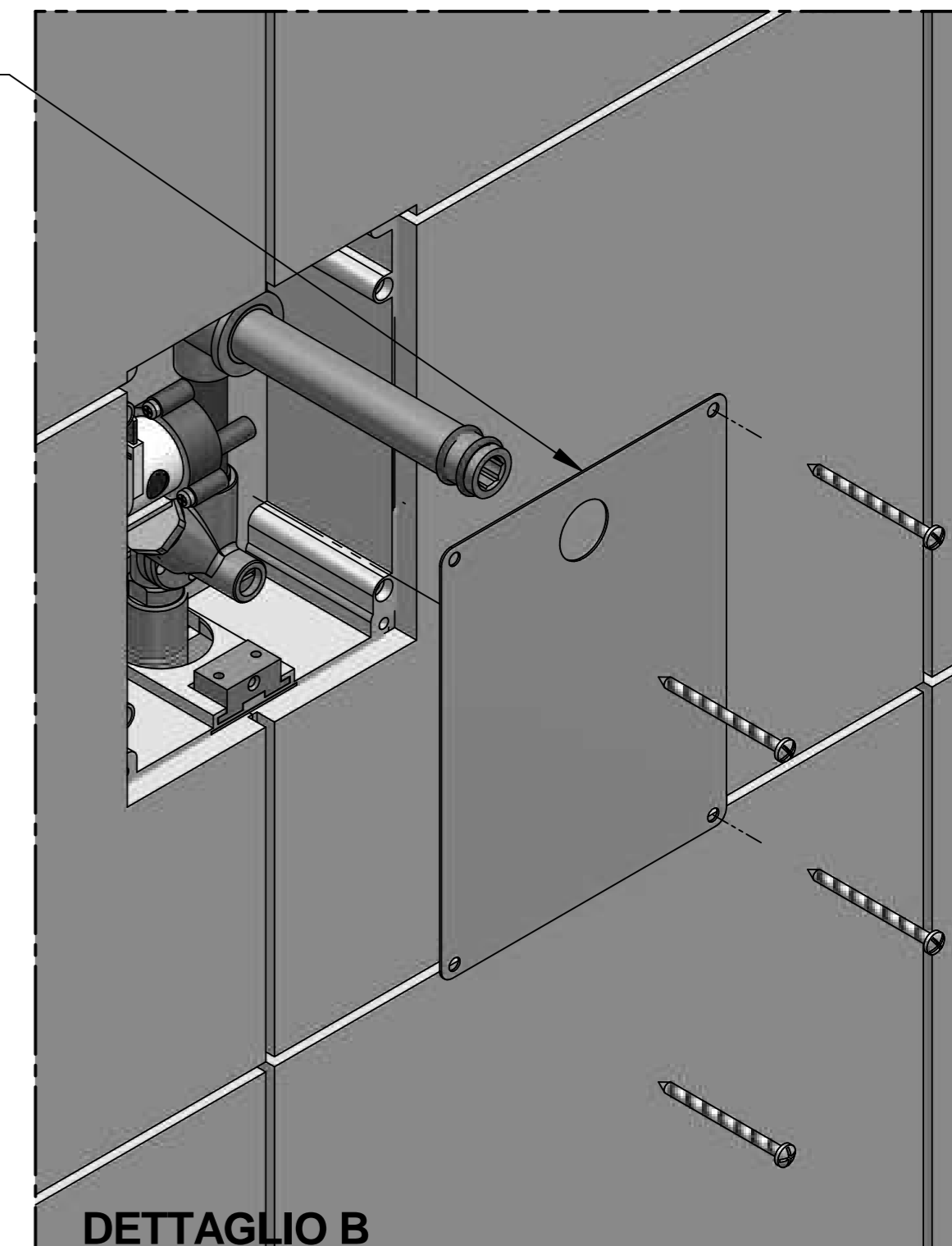
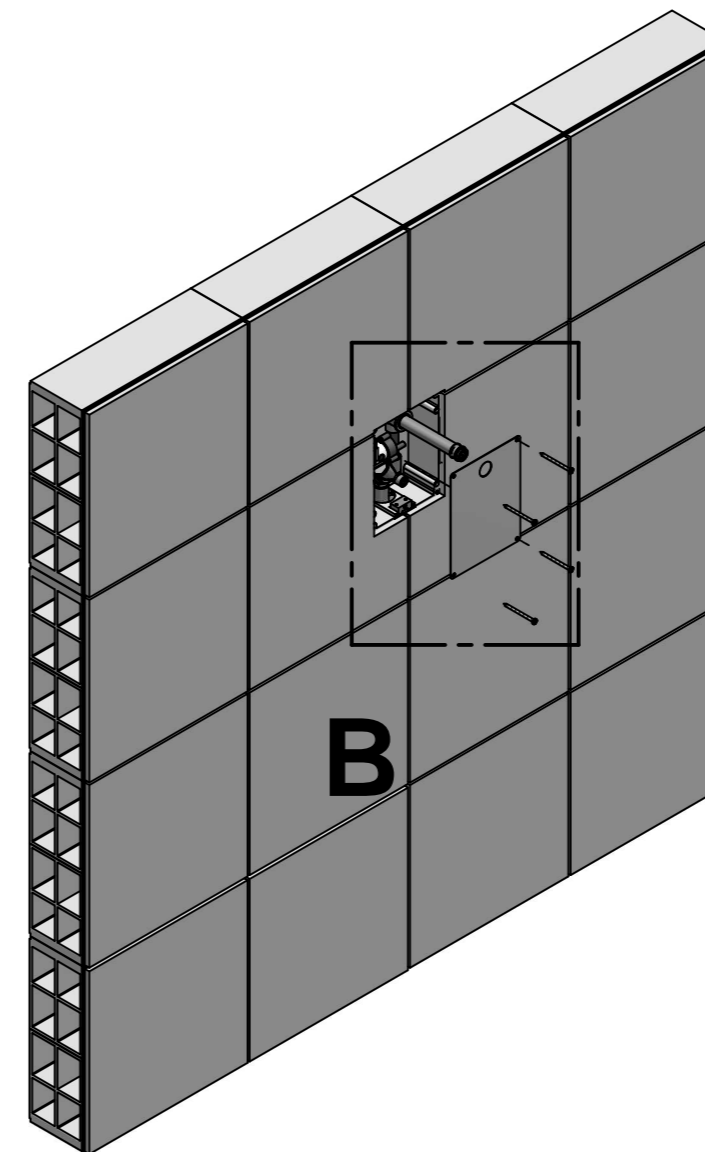

DETTAGLIO B

COLLEGARE IL FILO ROSSO(+) E IL FILO NERO(-).

CONNECT THE RED AND THE BLACK CABLE.

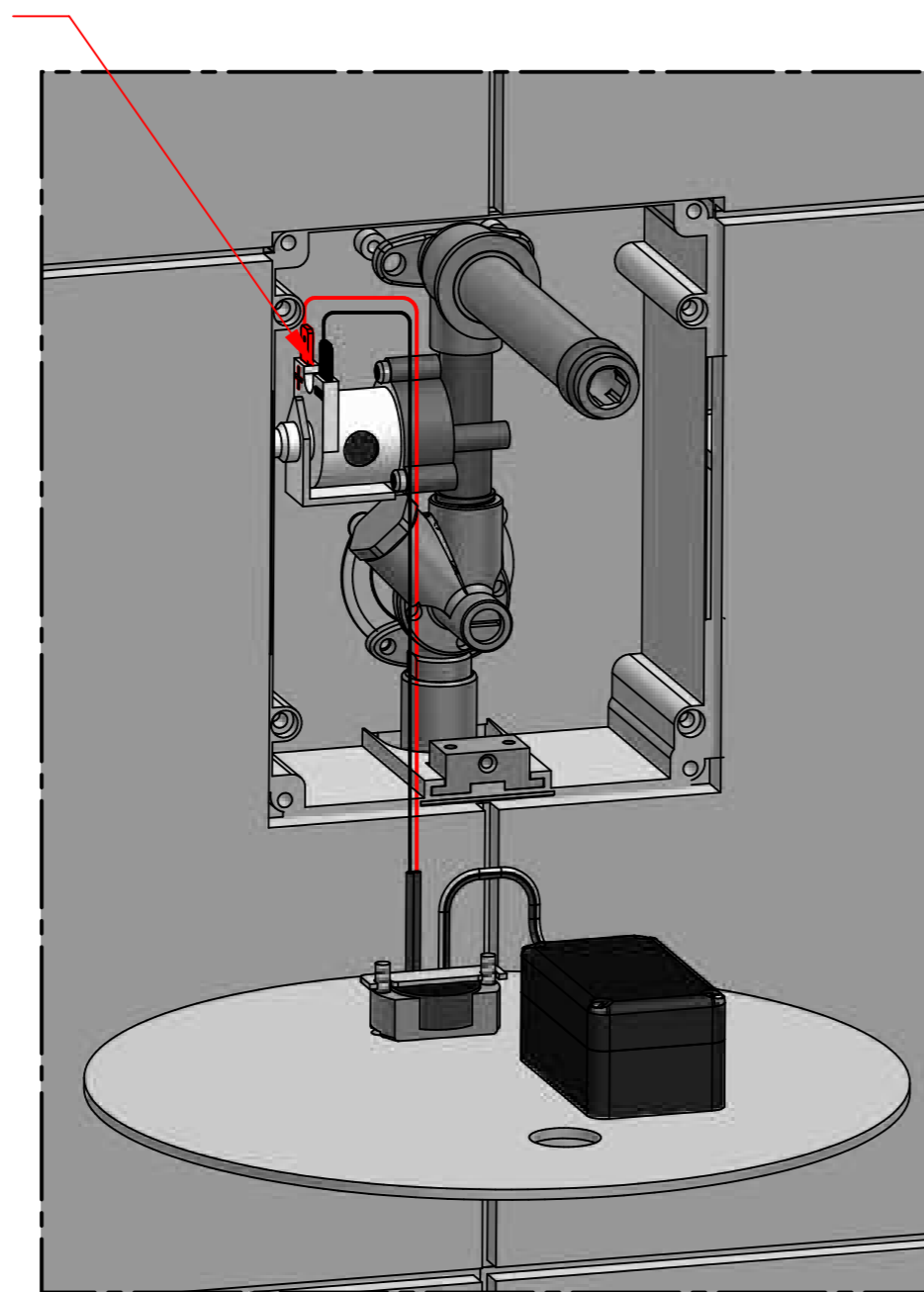
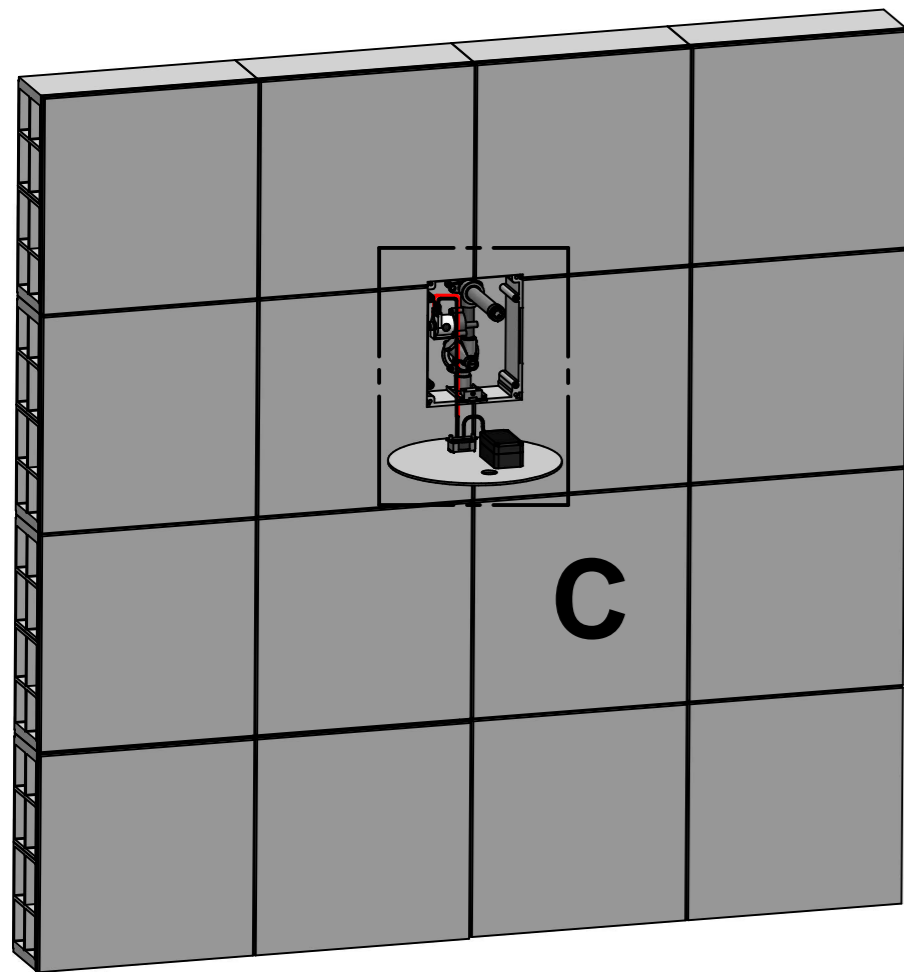

DETTAGLIO C

bongio

INSERIRE LA BATTERIA FACENDO ATTENZIONE HA NON INVERTIRE I POLI.

INSERT THE BATTERY AVOIDING TO INVERT THE POLES.

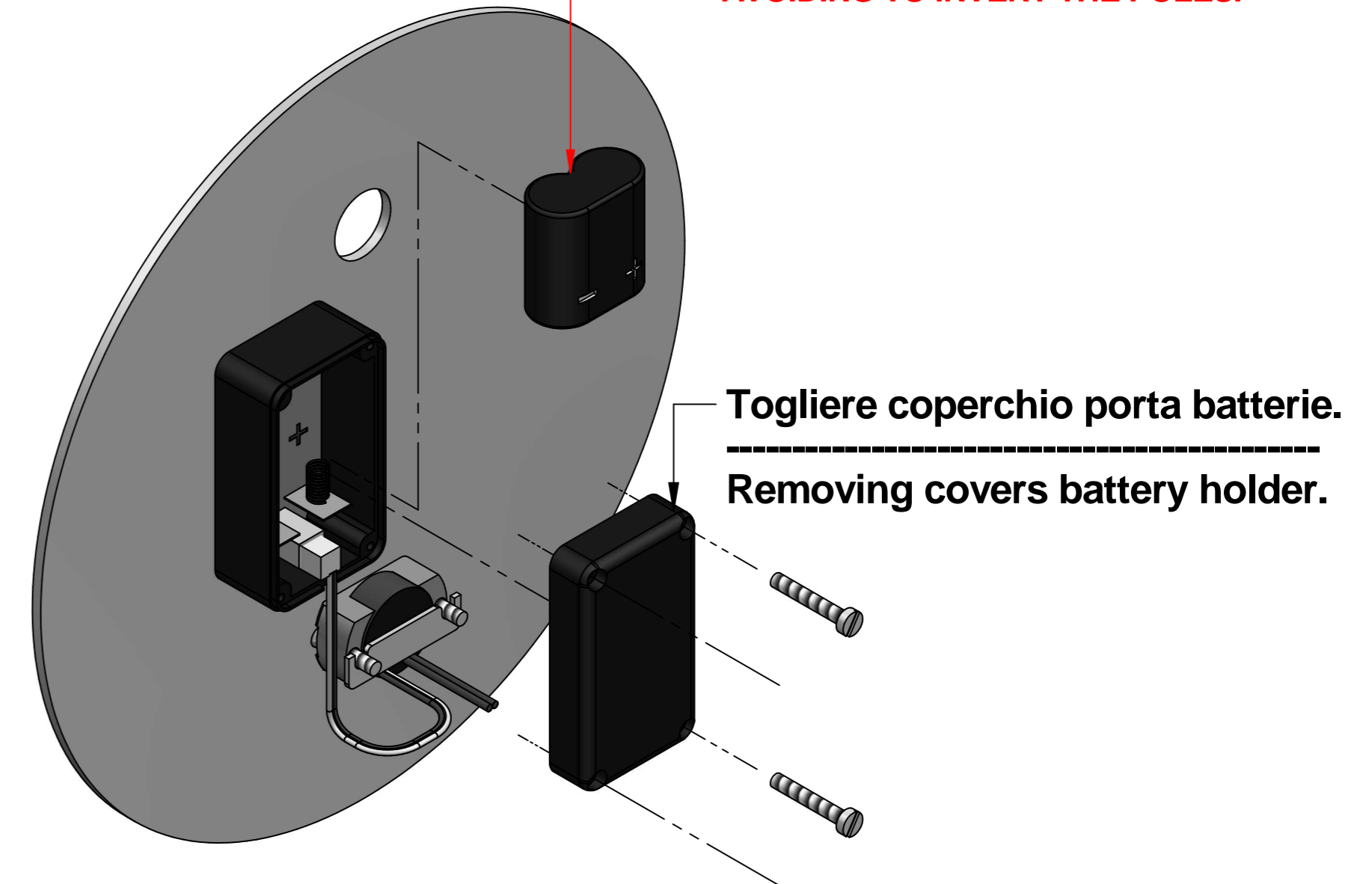

Togliere coperchio porta batterie.

Removing covers battery holder.

COLLEGAMENTO:

ATTENZIONE: Effettuare sempre i collegamenti elettrici prima di inserire la pila.

1. Collegare il faston di colore rosso al positivo (+) della bobina dell'elettrovalvola.
2. Collegare il faston di colore nero al negativo (-) della bobina dell'elettrovalvola.
3. inserire la pila al lithio nel porta batterie osservando il giusto posizionamento

Per non cambiare la distanza memorizzata quando si sostituisce la pila, bisognerà prestare attenzione di non mettere nulla davanti al sensore mentre il led lampeggia.

FUNZIONAMENTO:

Mettendo le mani davanti alla rubinetta, l'elettrovalvola si apre dopo un breve istante e rimane aperta per tutto il tempo in cui le mani sono nella zona di lettura. Un temporizzatore mantiene aperta l'elettrovalvola per due secondi dopo aver tolto le mani dalla zona di lettura. Un temporizzatore di sicurezza chiude l'elettrovalvola dopo 30 secondi di continua erogazione. Il led rosso visibile all'interno del sensore, lampeggia quando si deve sostituire la pila.

CONNECTION :

ATTENTION: Make the wiring before inserting the battery.

- 1) Connect the red faston to the positive (+) bobbin of the electrovalve.
- 2) Connect the black faston to the negative (-) bobbin of the electrovalve.
- 3) Insert the lithio battery into the box taking care of the correct position.

If you don't want to change the stored distance pay attention before removing the battery not to put anything in front of the sensor when the led flashes.

FUNCTIONING:

If you place the hands in front of the tap, the electrovalve opens after a second and remains opened until the hands remain in the reading point. A timer keeps the electrovalve opened for 2 seconds after you remove the hands from the reading point. A security timer closes the electrovalve after 30 seconds of continuous flow. The red led visible inside the sensor flashes when it's necessary to change the battery.

INSERIRE LA PIASTRA
INSERT THE PLATE

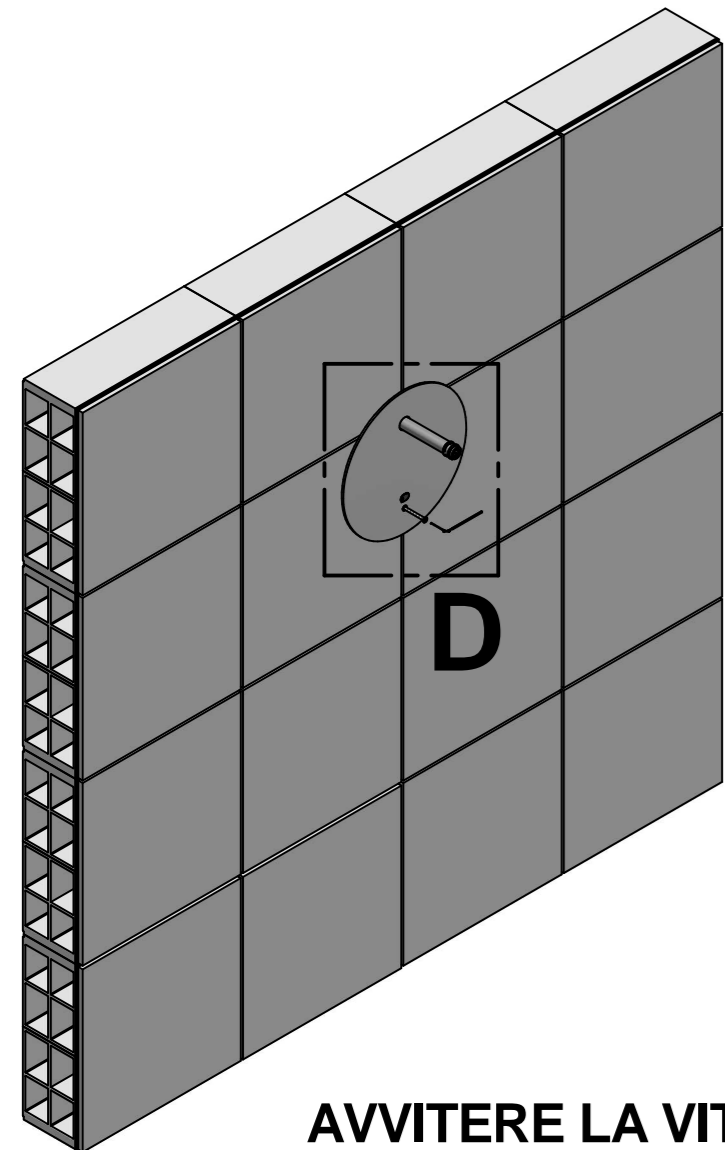

D

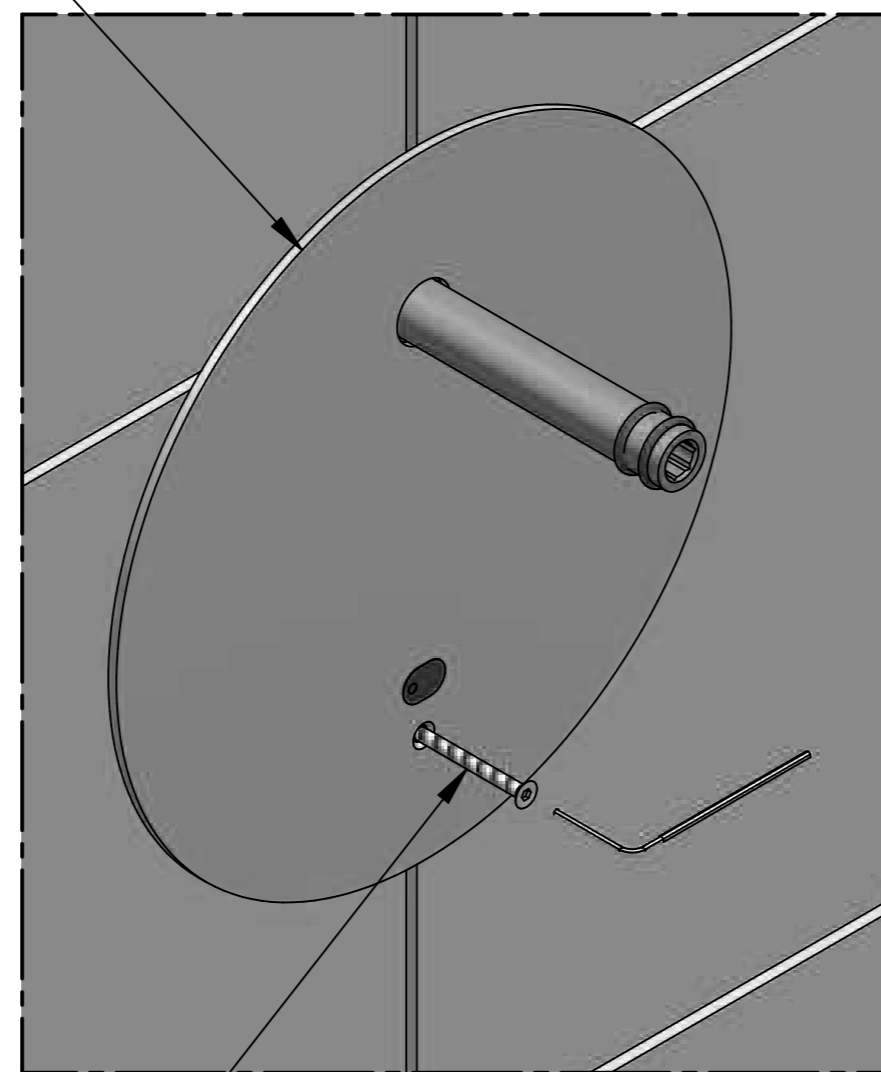

DETTAGLIO D

AVVITERE LA VITE DI FISSAGGIO.
SCREW THE FIXING SCREW.

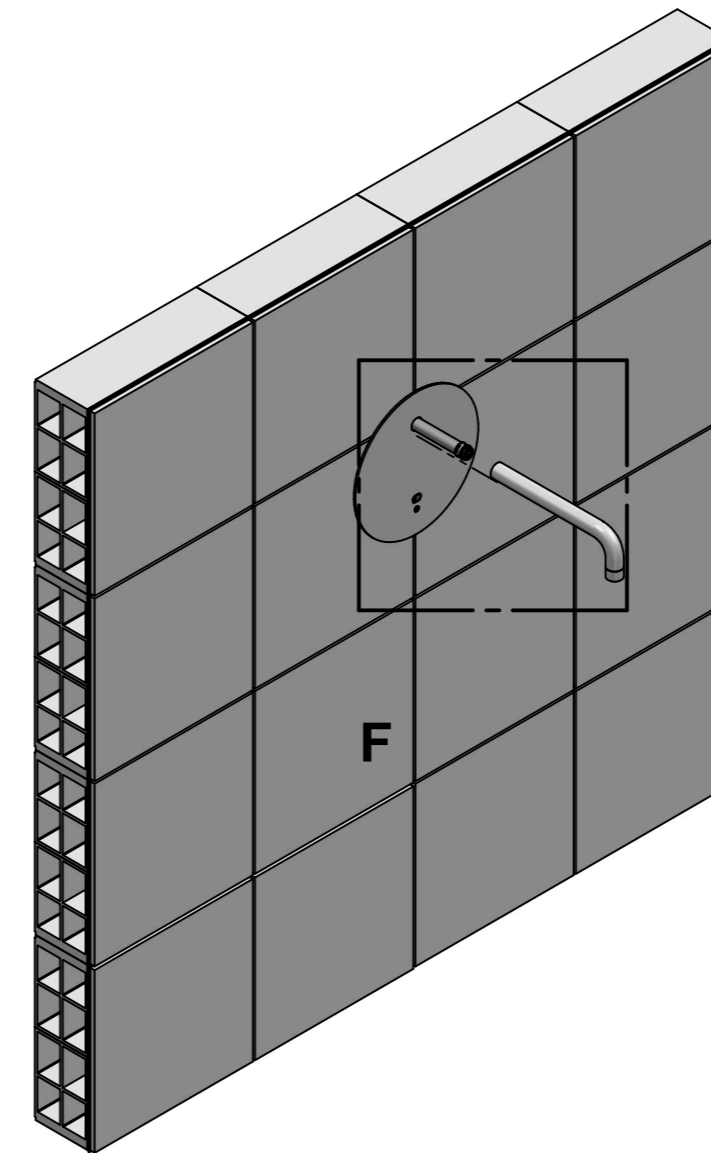

F

DETTAGLIO F

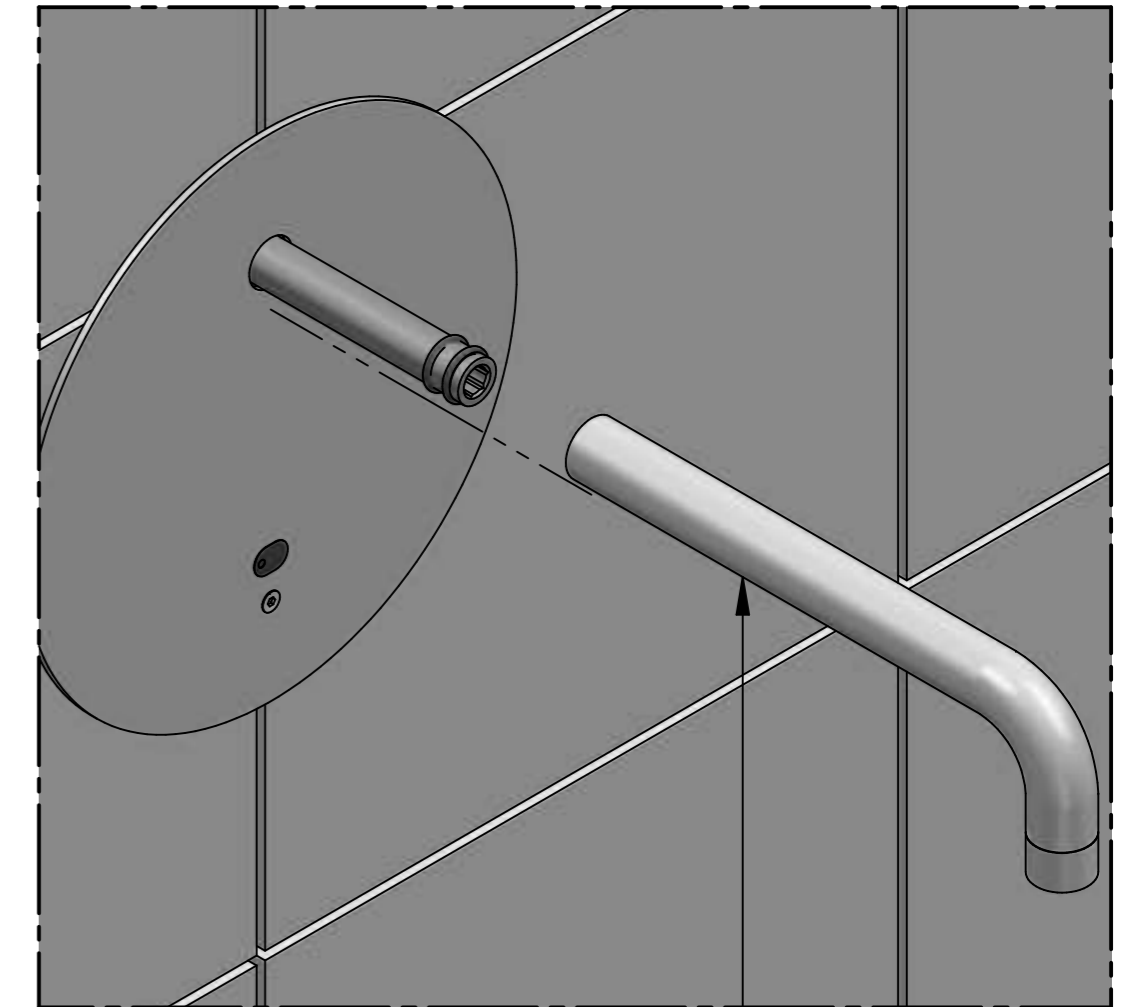

INSERIRE LA BOCCA.
INSERT THE SPOUT

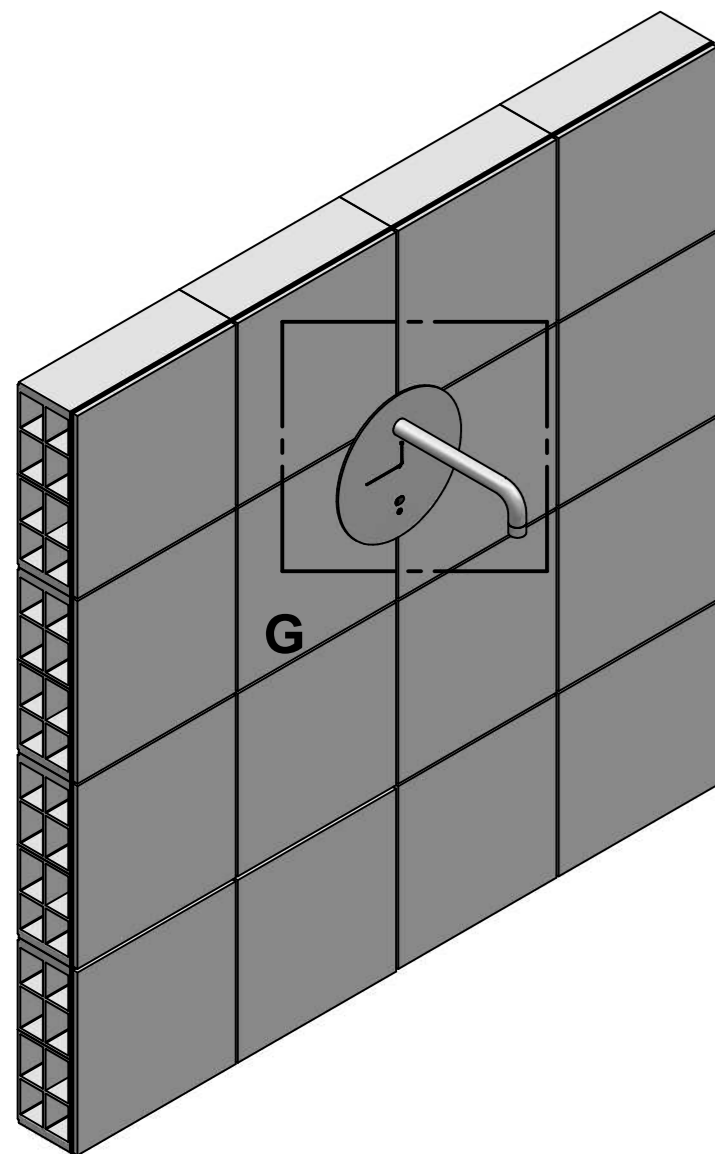

G

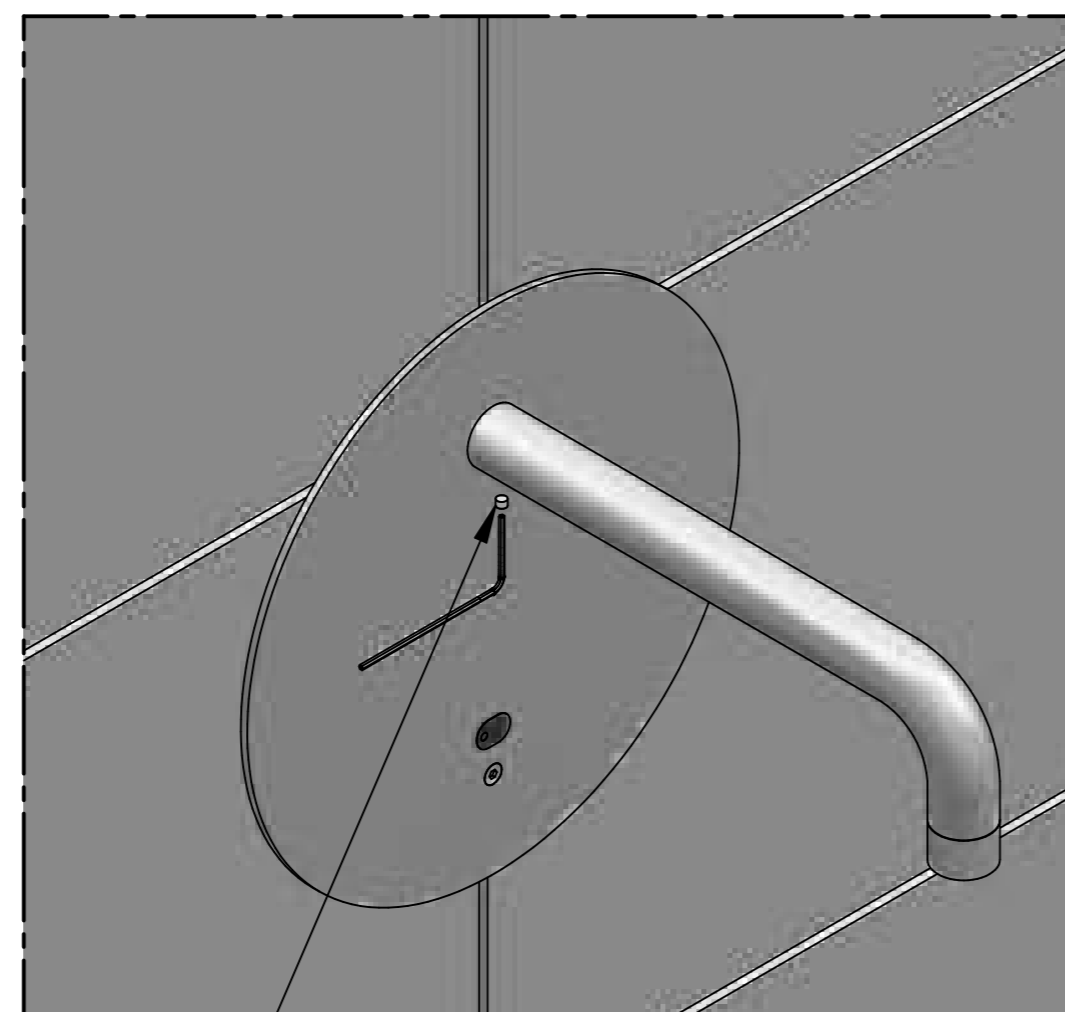

DETTAGLIO G

FISSARE LA BOCCA CON CHIAVE DA 2.
FIX THE SPOUT USING THE RELATIVE KEY

REGOLAZIONE:

Per modificare la distanza di lettura seguire le seguenti istruzioni:

1. Togliere la pila dal porta batterie.
2. Attendere qualche secondo e riposizionare la pila.
3. Mentre il led lampeggia, mettere una mano davanti al sensore a meno di cinque centimetri di distanza.
4. Quando il led rosso rimane fisso spostare la mano alla distanza desiderata.
5. Attendere che il led rosso si spenga prima di togliere la mano.
6. Una volta che il led rosso si è spento la distanza resta in memoria.

Per non cambiare la distanza memorizzata quando si sostituisce la pila, bisognerà prestare attenzione di non mettere nulla davanti al sensore mentre il led lampeggia.

SETTING :

To modify the reading distance follow these instructions:

- 1) Remove the battery from its holder place.
- 2) Wait some seconds and insert the battery again.
- 3) When the led flashes, put your hands in front of the sensor at less than 5 cm distance.
- 4) When the red led remains fixed put the hand at the desired distance.
- 5) Wait until the red led turns off before removing the hand.
- 6) when the red led has turned off the distance has been memorized.

If you don't want to change the stored distance pay attention before removing the battery not to put anything in front of the sensor when the led flashes.

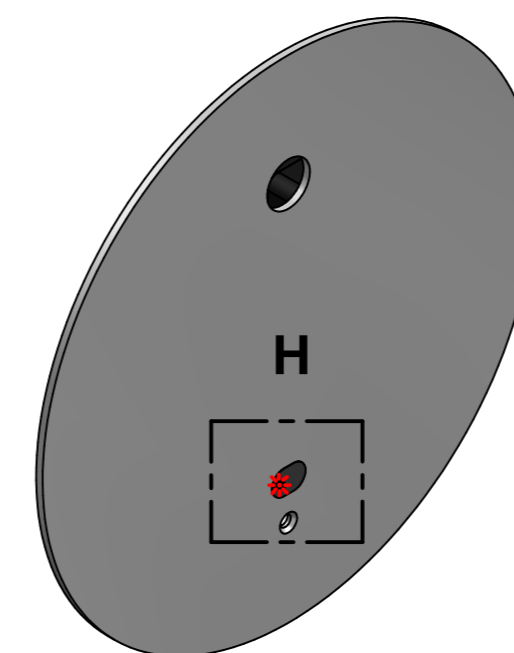

H

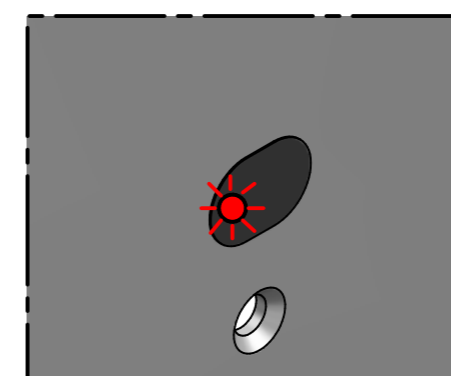

DETTAGLIO H