

# ISTRUZIONI DI MONTAGGIO

# INSTALLATION INSTRUCTIONS

Please read the following instructions carefully before using the products

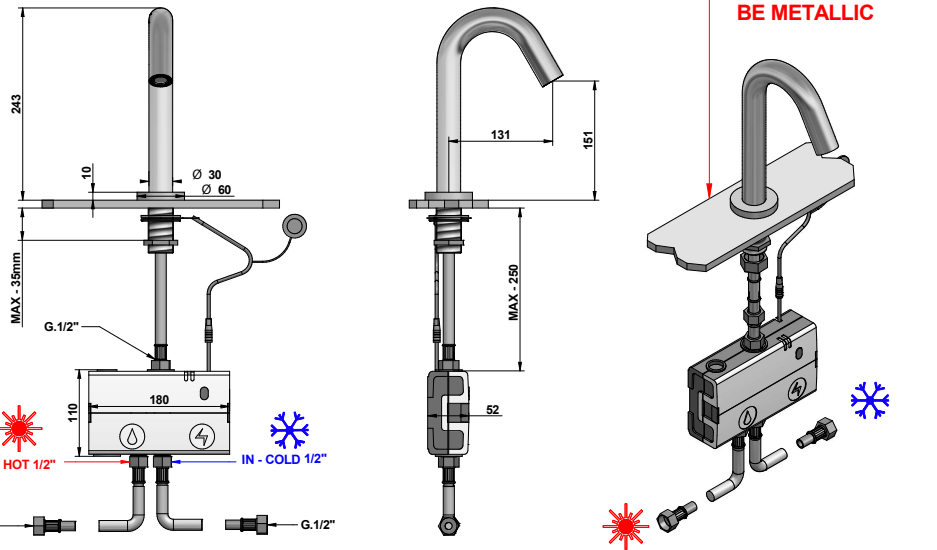

• Box (includes solenoid valve/clarinet, and battery holder)

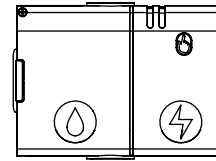

• Sensor cable

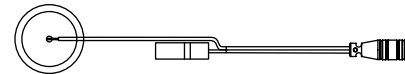

• Electrode washer



included

## OPERATING CONDITIONS

Fluid: Drinking water.

**Temperature:** Storage temperature between -20°C and 70°C (ensure that no water is inside the valve body). The valve is designed to operate with water temperatures between 5°C and 65°C.

**Operating pressure:** The valve has been designed to function with pressures between 0.5 and 8 bars.

**Recommended operating pressure:** 1 to 5 bars.

**Hydraulic connection:** G1/2" male threads.

**Flow direction:** Unidirectional (according to arrow on the valve side or bottom).

## CONDITIONS OF USE

To activate the faucet, the user must place their hands directly underneath the faucet; the water starts to flow automatically.

The water flow stops automatically 1s\* after hands are removed from the faucet's proximity.

If detection occurs for more than 12s\*, then a security time-out automatically shuts-off the water flow.

Normal operation can resume once the object or hand leaves the detection zone.

\*Modifiable

## STORAGE GUIDELINES

Always store boxes in their original packaging so that the product can be immediately identified easily. Following reception and inspection, the product must be placed back into its original packaging and stored as such up until the moment that the product is installed. Store boxes, within their original packaging, in a cool dry space protected from humidity, heat, frost and wind (can potentially carry solid particles such as earth, sand or cement). When testing in quality control, take care of the water quality: clear water and no silicone residue.

## HANDLING GUIDELINES

Avoid damaging shocks and impacts with the box and threaded ends. The box must be handled with caution, any impact can weaken the resistance of the plastic body or cracks that could cause leaks as the product ages.

## ASSEMBLY INSTRUCTIONS

The box must be installed in conformity with the relevant standards and national regulations. Before installation and once the packaging is removed, check that the box is clean, and that it has not been damaged by impacts that may have occurred during the product's transportation. Check that the seals and threaded ends of the box are clean.

## INSTALLATION INSTRUCTIONS

The C Flex Box should be isolated from other electrical machines that do not respect relevant EMC standards for sanitary ware installations.

All connections must be carried out in accordance with applicable standards (EN 806-4, for example) and the instructions that are detailed within this manual. Several flushes of the water pipes must be carried out prior to installation in order to eliminate dust, debris and residue from soldering fluxes. Water piping must be perfectly clean prior to the installation of the box. It is essential to allow for the possibility that the box be uninstalled at a later date (ensure that hydraulic connections are accessible, wrench passage etc.). The box must remain accessible to allow for maintenance operations (cleaning/changing filter, changing batteries for example).

Before installation turn off the water supply and check that you have all the necessary equipment.

A

Flange with fasten terminal for the earthed body of the tap.

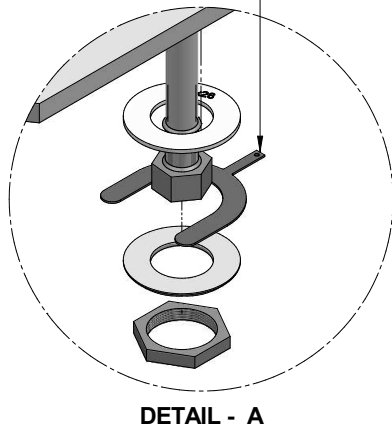
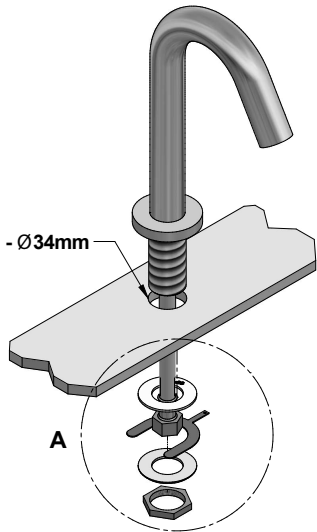

## PREPARE THE BOX

A - First unscrew the two screws.

B - Remove the cover  
Press the blue parts and pull the white flaps on both sides of the box

C - Remove the valve and the battery holder.

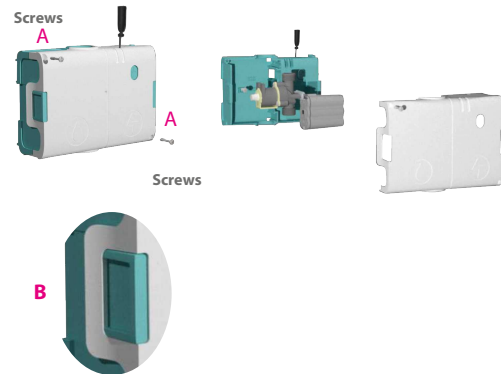

B

## FIX THE BOX

Start by determining the correct position for the box:

Ensure that its position allows you to make the hydraulic connections without creating unnecessary stress on the water hoses.

Check that the water hoses are the right length and do not rely on the box to absorb the differences (risk of compromised water tightness, non-operation and even burst).

Check that the sensor cable will be able to reach the electrode washer underneath the faucet.

Make sure that the box will not bear the weight of the water hoses or be placed under strain by the installation.

Once this has been checked, hold the box in place in the optimum position. Use a pencil to mark the position of the box's screw channels on the wall. Remove the box from the wall then drill and install the screws at the points marked on the wall.

Fix the box to the wall.

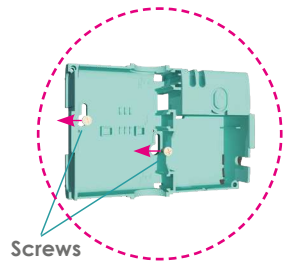

**bongio**

Istruzioni montaggio  
Per Art - 70501-EL

Installation instruction  
For item - 70501-EL

Mario Bongio s.r.l.  
Via Aldo Moro, 2  
28017 San Maurizio d'Opaglio (NO) - Italy  
tel: +39 0322 967248 fax: +39 0322 950012  
www.bongio.com

# ISTRUZIONI DI MONTAGGIO

# INSTALLATION INSTRUCTIONS

C

## ATTACH THE WATER HOSE

- A - Attach water hose to the valve's inlet.\*
- B - Attach water hose to the valve's outlet.\*

Ensure that the diameter of the water hoses are suitable for the valve's connectors. The standard valve connector has a 1/2" diameter.\*\*

\*please respect the below hydraulic connection recommendations.  
\*\* Other connector sizes are available for the basic solenoid valve (valve on left side), see technical note.



## PRECAUTION FOR HYDRAULIC CONNECTIONS

Water tightness is preferably guaranteed by a flat seal placed between the valve thread and the hoses: ensure that seals have the correct dimensions, are clean and without defect, whilst checking that the seals are fit for purpose.

Hold the valve during the connection with water hoses, and avoid excessive strain on its hydraulics. Screw by hand to ensure correct alignment with the box's thread then screw until the mechanical stop.

Finish the attachment by using an appropriate wrench and making a ¼ turn (maximum); maximum tightening torque 5 N m.

Do not clamp the box inlet or outlet with wrench or other tools in order to avoid damage to the body's exterior surface and premature wear of internal components.

Replace the valve in the box according to the pictogram on the base of the box.

D

## INSTALL THE SOLENOID VALVE

Replace the valve in the box according to the pictogram on the base of the box. The valve's position in the box varies depending on the configuration type: single flow, premix or dual flow (see visual).

Once the valve is securely placed in the box, connect the solenoid valve's cable to the box's corresponding red and black cable.

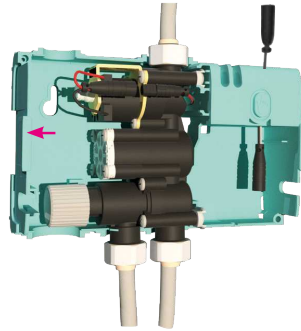

E

## CONNECT THE SENSOR CABLE

A - Remove the double-sided tape under the cable PAD, then stick it on the wall behind the faucet, as far away from the faucet as possible.

The wire cannot touch any other conductive material.

B - Clip the sensor cable to the electrode washer, again making sure that the wire is not in contact with other conductive material.

C - Connect the sensor cable connector to the box.

Ensure that the sensor cable is not stretched or in contact with the water hoses.

D - Use the small adhesive pad to attach the sensor cable to the wall.

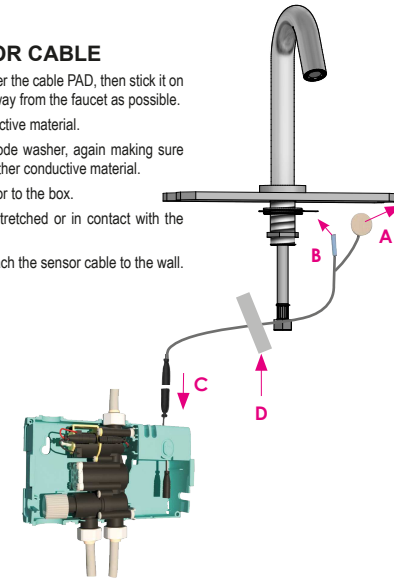

F

## INSERT AND CONNECT BATTERIES

A - Place 6 AA batteries in the battery holder according to polarity.

B - Place the battery holder in the box.

C - Plug the battery holder to the corresponding connector in the box (connector with black and grey cable).

Respect the order of sequence A,B and C.

By connecting the power, the system's calibration sequence is launched (STEP 10).

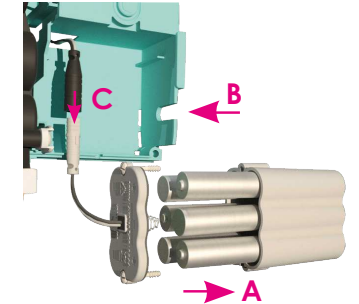

G

## CALIBRATION

Immediately after connecting the power supply, stand at a distance of 1 metre away from the faucet.

Make no contact with the faucet, box or any components of the installation.

During calibration, the green led flashes and water flows from the faucet for 10s. Once the water has stopped flowing, approach hands towards the faucet body until the water flows again. The water stops flowing automatically in less than 1s.

If the calibration is successful, the green light stop flashing and the faucet releases a short burst of water (<1s).

If the calibration is unsuccessful, the box's red led lights up and faucet releases two short bursts of water.

In this case, unplug and reconnect the box's batteries in order to reinitiate the calibration process. If the problem persists consult troubleshooting guidance.

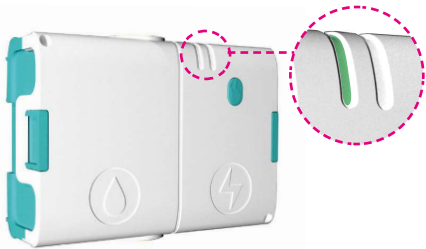

H

## ADJUST SENSITIVITY IF NECESSARY

After the calibration phase, activate and deactivate the faucet 3 to 4 times. This should allow the sensor to automatically optimise sensitivity to its installation conditions but if the sensor sensitivity is not satisfactory press the button to adjust it. Throughout the product's lifetime the sensor will auto-calibrates to ensure that the system maintains a stable performance.

The sensor has 5 levels of sensitivity:

- Level 1: very low sensitivity
- Level 2: low sensitivity
- Level 3: medium sensitivity
- Level 4: high sensitivity
- Level 5: very high sensitivity

To adjust the sensitivity:

- The level of sensitivity can be set by using the green button.
- To enter sensitivity adjustment press the green button for 10 (until the green led is permanently lit).
- Release the button.

The sensitivity level is indicated by a series of flashes. For example, level 2 is indicated by 2 flashes.

Each time the button is pressed the sensitivity level increases by 1. At level 5, press once more and the system returns to level 1.

After adjusting the level, press the button for 5 seconds to validate. Both leds flash once to confirm that the sensitivity level has been validated.

After adjustment the system reboots and restarts an autocalibration cycle. (STEP 10)

If the sensitivity level is not validated, the led continues to flash for 5 minutes before stopping without saving the new sensitivity level.

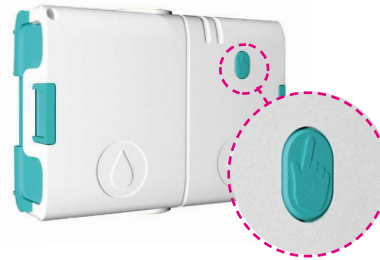

I

## LOW BATTERY

- 1 blink every 5 seconds

When batteries reach a low level the box's red LED blinks every seconds. The batteries are nearly empty and need to be changed quickly before the system shuts off. It takes on average 10 days for the system to go from low battery to the shut off.

## EMPTY BATTERY

- 1 blink every 5 seconds, and no water.

The batteries are empty, the system has shut off the water, and the blinking continues until no power remains or the batteries are replaced.

## AQUASTOP

To ensure that the faucet doesn't open during cleaning, the aquastop function temporarily deactivates the sensor. To activate this function, press the control button and the sensor remains inactive for 30s.

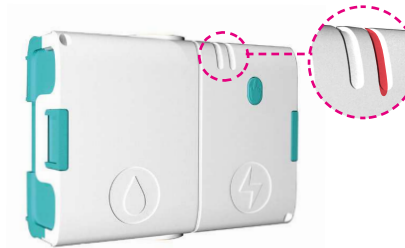

L

## FILTER MAINTENANCE

Depending on the installation's water quality it may be necessary to clean or replace the box's valve filter.

## FILTER CLEANING

Remove the valve from the box. Run water into the valve's inlet, whilst tilting the valve to the side to allow impurities to pour out into the sink.

## FILTER REPLACEMENT

Remove the valve from the box. Use a pair of tweezers to remove the filter from the valve. Put an identical filter in place with the filter grill facing outwards. Push the filter into the valve up until the mechanical

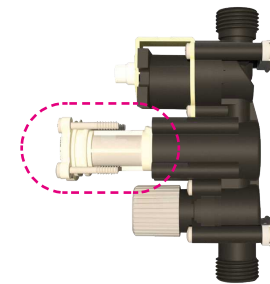

**bongio**

Istruzioni montaggio  
Per Art - 70501-EL

Installation instruction  
For item - 70501-EL

Mario Bongio s.r.l.  
Via Aldo Moro, 2  
28017 San Maurizio d'Opaglio (NO) - Italy  
tel: +39 0322 967248 fax: +39 0322 950012  
www.bongio.com