

MIN 71mm - MAX 85mm

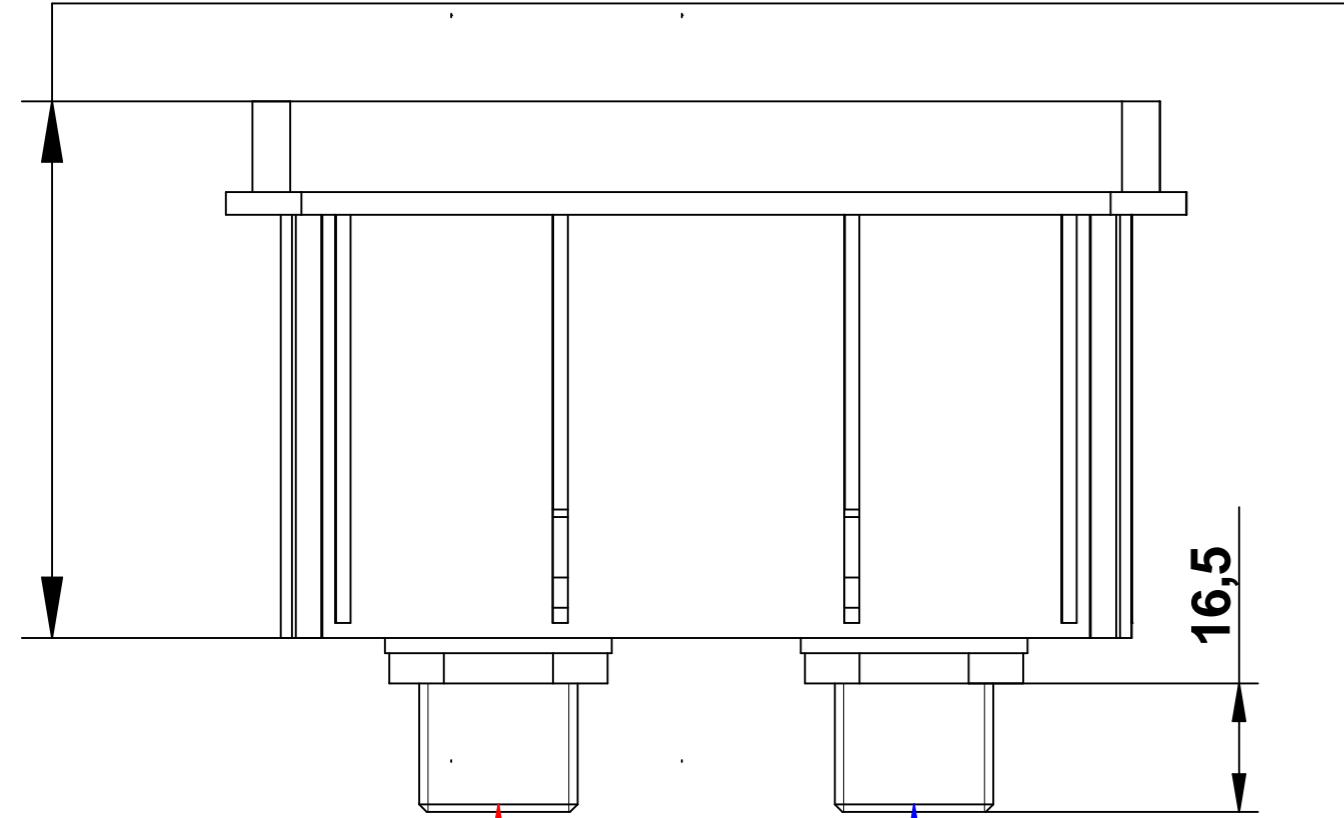

**IN-F.1/2" Gas
HOT - CALDO**



**IN-F.1/2" Gas
COLD - FREDDO**

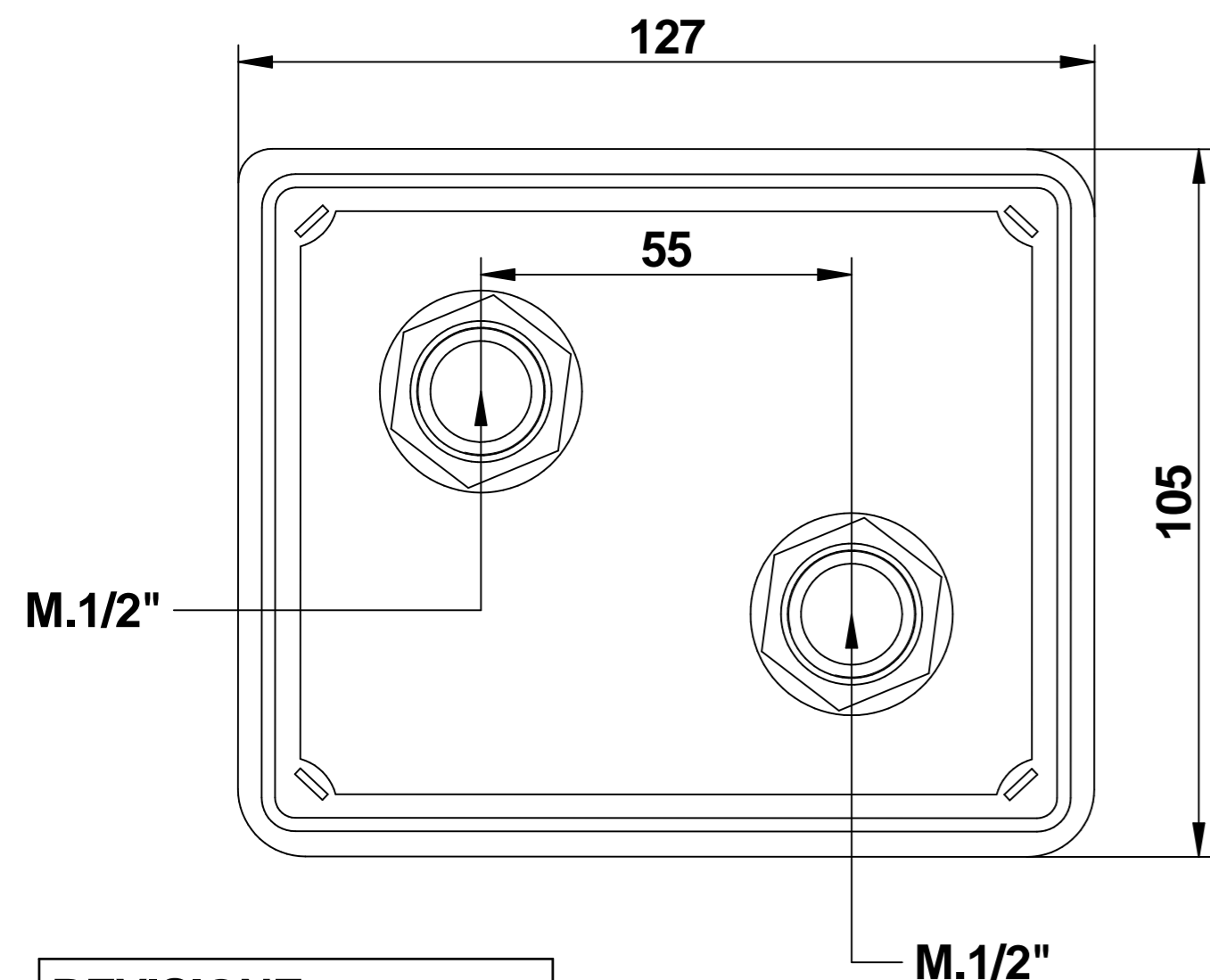
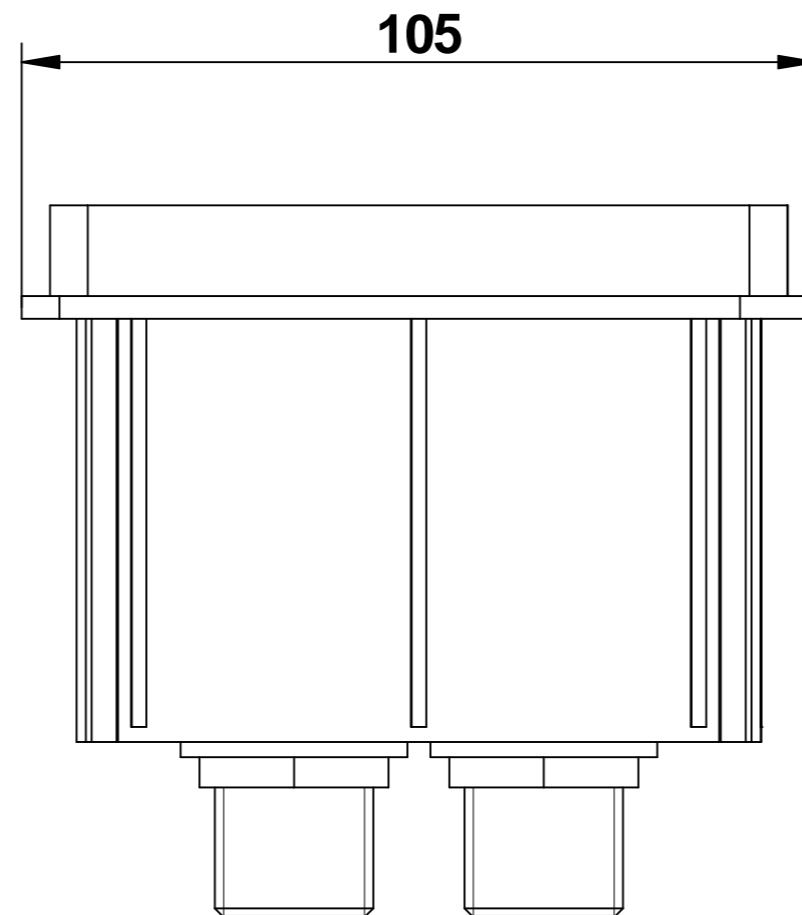

REVISIONE
00 DEL 2025

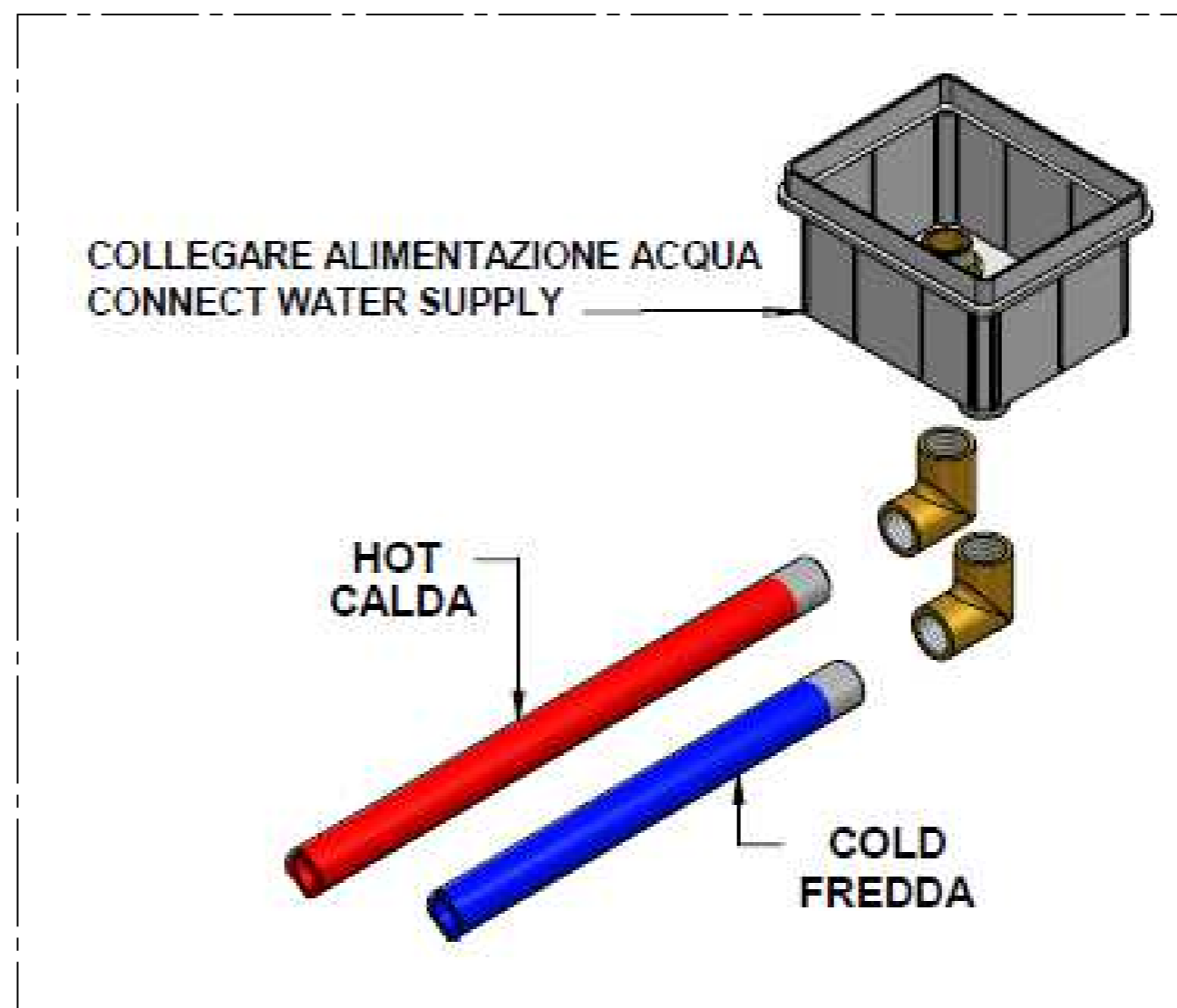

MINIMUM WORKING PRESSURE:.....0,5 bar
 MAX OPERATING PRESSURE:.....5 bar
 RECOMMENDED OPERATION PRESSURE:.....3 bar
 MAX HOT WATER TEMPERATURE:.....80°C
 RACOMMANDED HOT WATER TEMPERATURE:.....60°C

In case of operating pressures higher than 5 bar it is recommended to install a pressure reducer on the feeding tubes.

PRESSIONE MINIMA DI SERVIZIO:.....0,5 bar
 PRESSIONE DI SERVIZIO MASSIMA:.....5 bar
 PRESSIONE D'USO CONSIGLIATA:.....3 bar
 TEMPERATURA ACQUA CALDA MAX:.....80°C
 TEMPERATURA ACQUA CALDA CONSIGLIATA:.....60°C

In caso di pressione d'esercizio superiore a 5 bar è consigliabile installare un riduttore di pressione sulle tubatura di alimentazione

32131SCAT

CORPO INCASSO

Corpo incasso

Built-in body

32131__EU

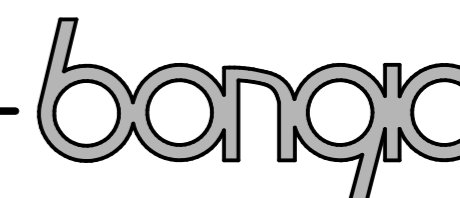

Mario Bongio s.r.l.
 Via Aldo Moro, 2
 28017 San Maurizio d'Opaglio (NO) - Italy
 tel: +39 0322 967248 fax: +39 0322 950012
 www.bongio.com