

IN-F.1/2" Gas
COLD - FREDDO ❄️

F. 1/2" Gas.
USCITA - EXIT

❄️ IN-F.1/2" Gas
COLD - FREDDO

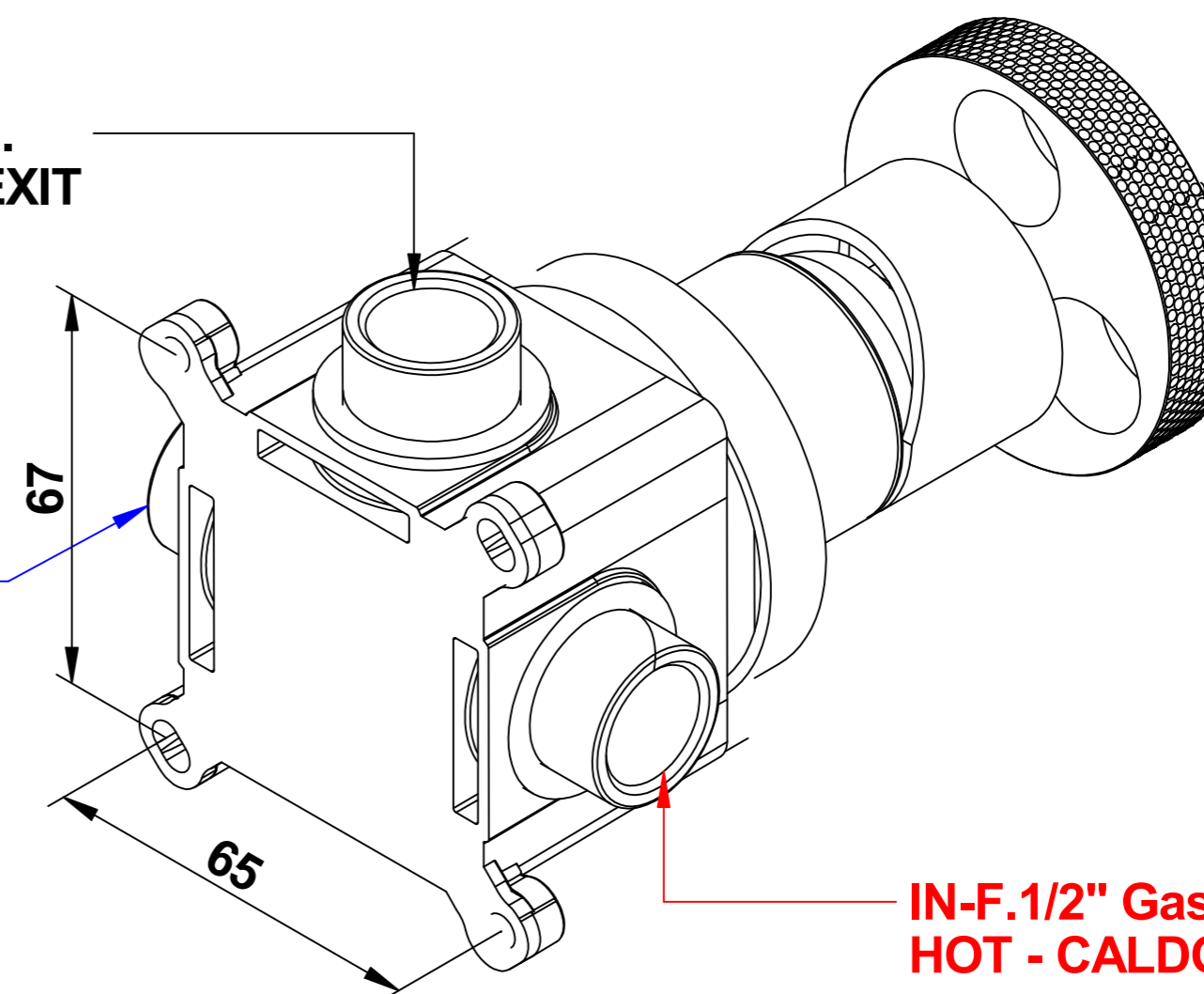

IN-F.1/2" Gas
HOT - CALDO ☀️

REVISIONE
00 DEL 2025

38524 _____ **EU+9761SC01**
BOWLING

**Miscelatore incasso con rosone
piccolo completo di scatola
incasso**

**Built-in mixer with small
flange and built-in box**

© Copyright of Mario Bongio s.r.l.

bongio
Mario Bongio s.r.l.
Via Aldo Moro, 2
28017 San Maurizio d'Opaglio (NO) - Italy
tel: +39 0322 967248 fax: +39 0322 950012
www.bongio.com