

F. 1/2" Gas.
USCITA - EXIT

MIN 54mm. / MAX 74mm.

IN-F.1/2" Gas
HOT - CALDO

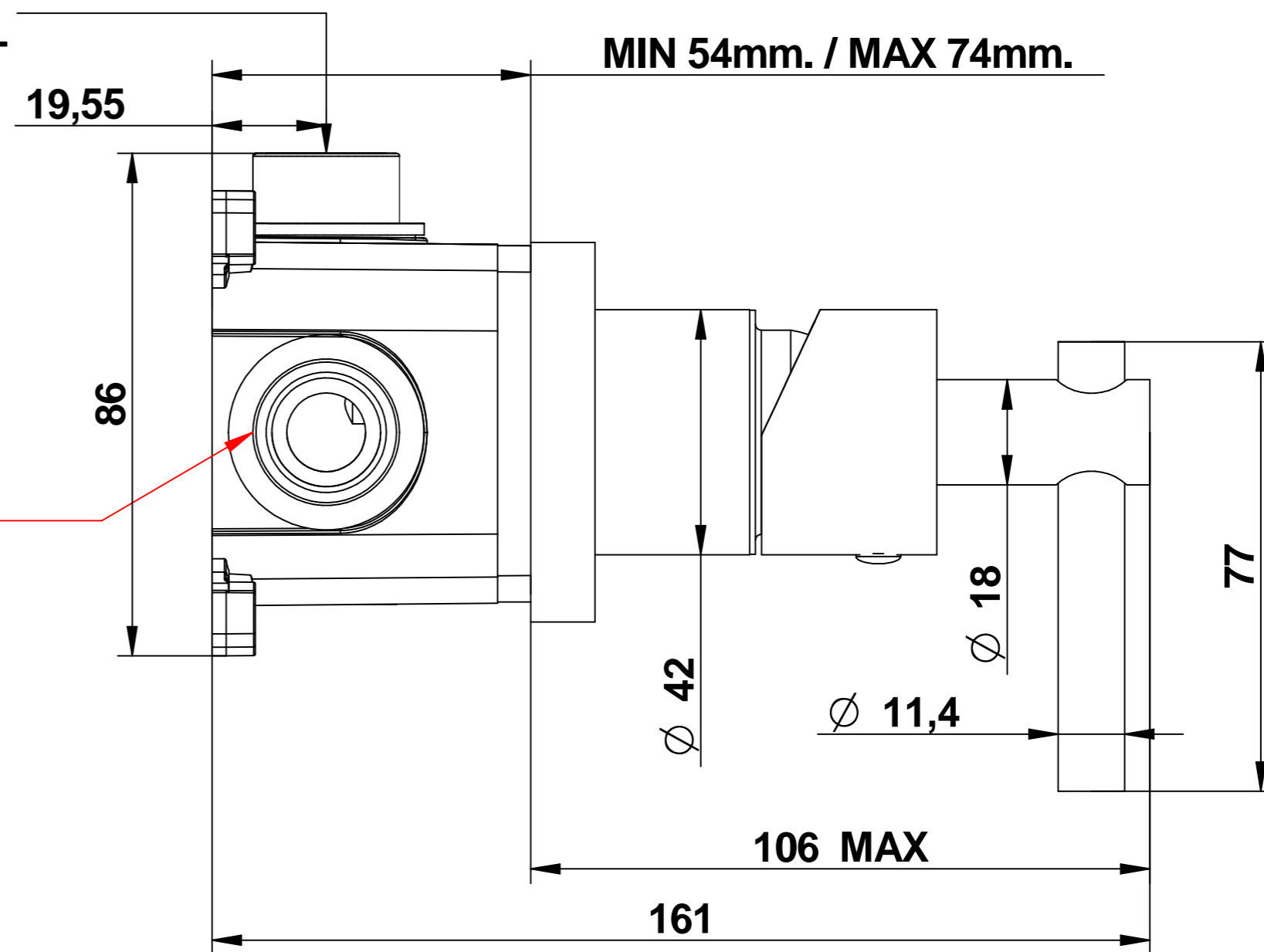

F. 1/2" Gas.
USCITA - EXIT

IN-F.1/2" Gas
HOT - CALDO

IN-F.1/2" Gas
COLD - FREDDO

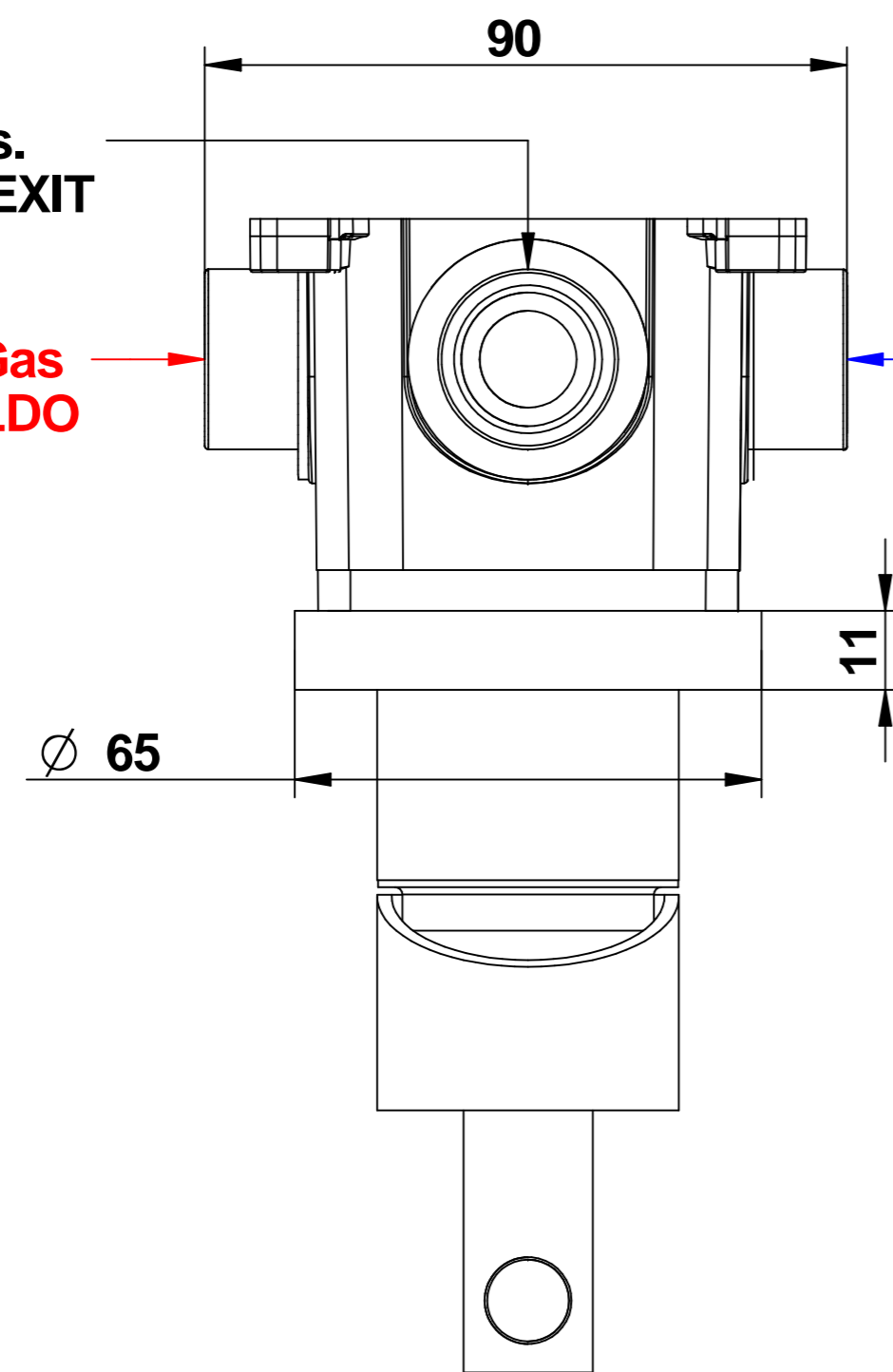

F. 1/2" Gas.
USCITA - EXIT

IN-F.1/2" Gas
COLD - FREDDO

IN-F.1/2" Gas
HOT - CALDO

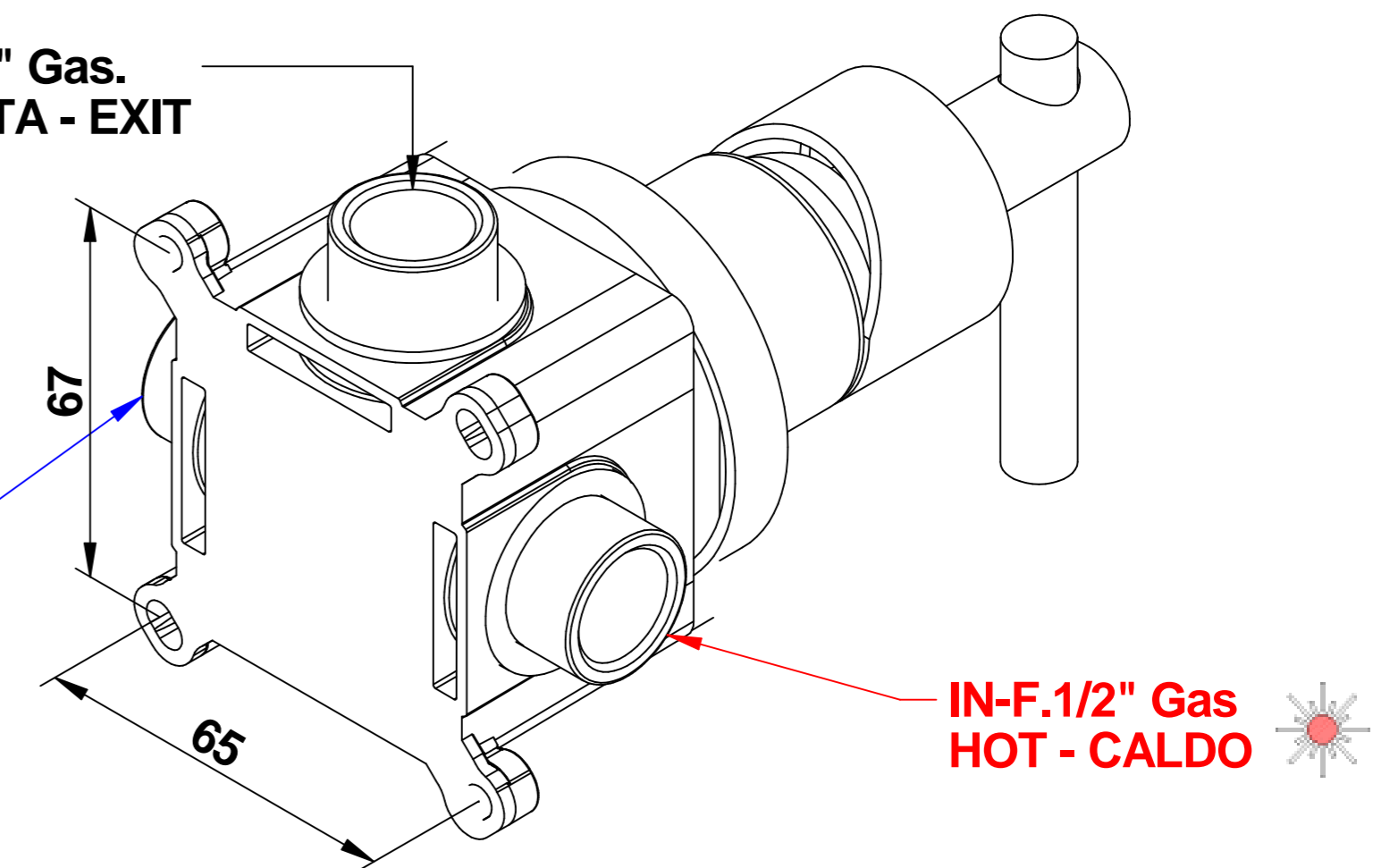

REVISIONE
00 DEL 2025

31324__RPEU+9761SC01
T.LEVER

**Miscelatore incasso con rosone
piccolo completo di scatola
incasso**

**Built-in mixer with small
flange and built-in box**

© Copyright of Mario Bongio s.r.l.

bongio

Mario Bongio s.r.l.
Via Aldo Moro, 2
28017 San Maurizio d'Opaglio (NO) - Italy
tel: +39 0322 967248 fax: +39 0322 950012
www.bongio.com