

F. 1/2" Gas.  
USCITA - EXIT

19,55

MIN 54mm. / MAX 74mm.

IN-F.1/2" Gas  
HOT - CALDO

86

97

Ø 42

10

79 MAX

133

F. 1/2" Gas.  
USCITA - EXIT

IN-F.1/2" Gas  
HOT - CALDO



IN-F.1/2" Gas  
COLD - FREDDO

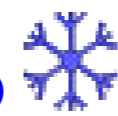

F. 1/2" Gas.  
USCITA - EXIT

IN-F.1/2" Gas  
COLD - FREDDO

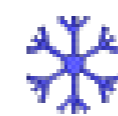

IN-F.1/2" Gas  
HOT - CALDO

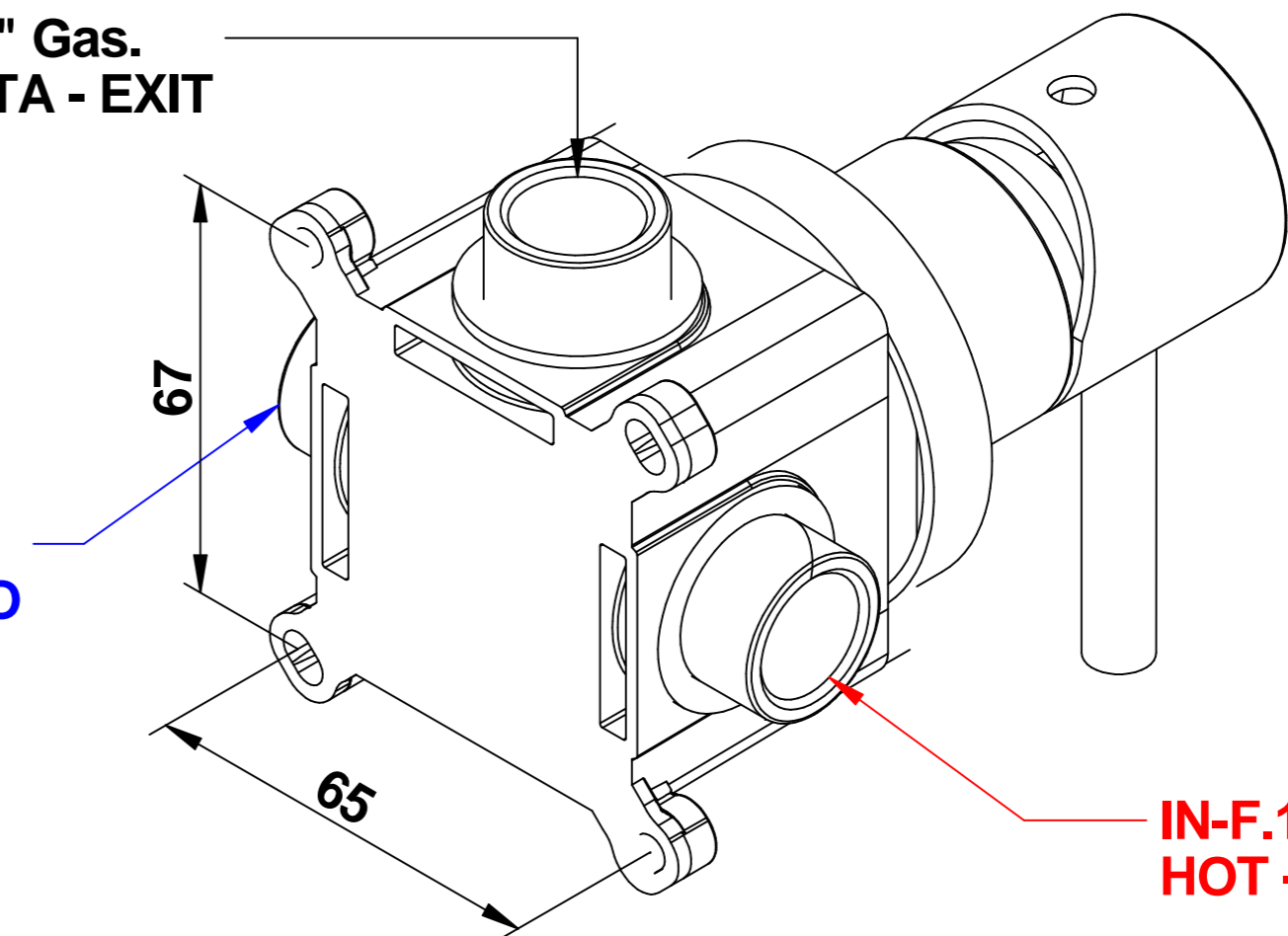
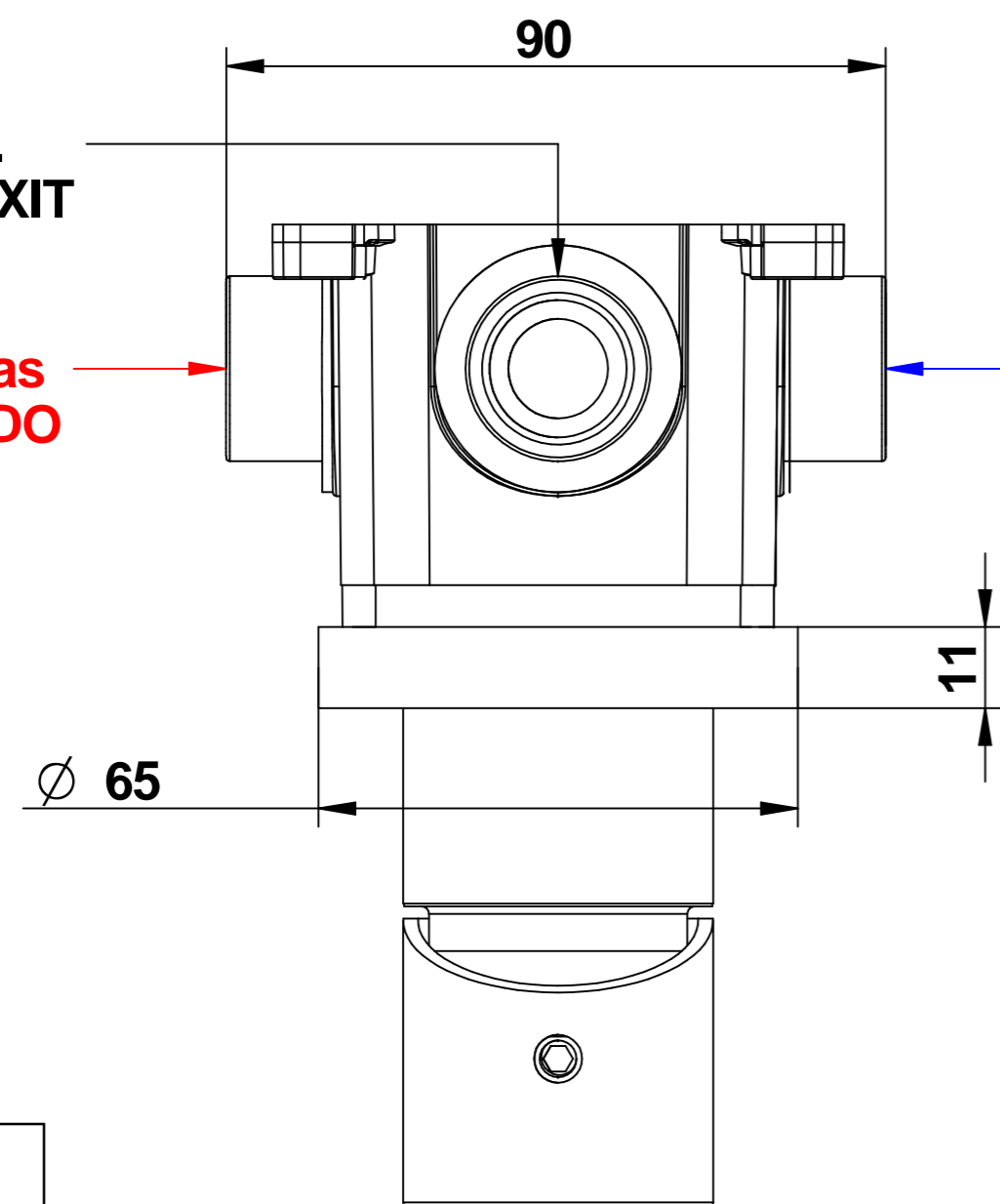
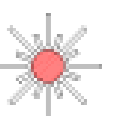

REVISIONE
00 DEL 2025

**68524\_\_RPEU+9761SC01**  
**ON**

Miscelatore incasso con rosone  
piccolo completo di scatola  
incasso

Built-in mixer with small  
flange and built-in box

© Copyright of Mario Bongio s.r.l.

**bongio**

Mario Bongio s.r.l.  
Via Aldo Moro, 2  
28017 San Maurizio d'Opaglio (NO) - Italy  
tel: +39 0322 967248 fax: +39 0322 950012  
www.bongio.com